

Manual**Sensor Series A5S0**

(Original operating manual)

valid for versions

A5S0DD0	(1x speed,	signal range 0 Hz...25 kHz)
A5S0DD3	(1x speed / 1x direction,	signal range 0 Hz...25 kHz)
A5S0DD4	(2x speed, phase-shifted,	signal range 0 Hz...25 kHz)
A5S0DS0	(1x speed,	signal range 0 Hz...12 kHz)
A5S0DS3	(1x speed / 1x direction,	signal range 0 Hz...12 kHz)
A5S0DS4	(2x speed, phase-shifted,	signal range 0 Hz...12 kHz)

also valid for sensors with previous order code:

A5S05 to A5S09	(1x speed,	signal range 0 Hz...12 kHz)
A5S30 to A5S33	(1x speed / 1x direction,	signal range 0 Hz...25 kHz)
A5S40 to A5S43	(2x speed, phase-shifted,	signal range 0 Hz...25 kHz)

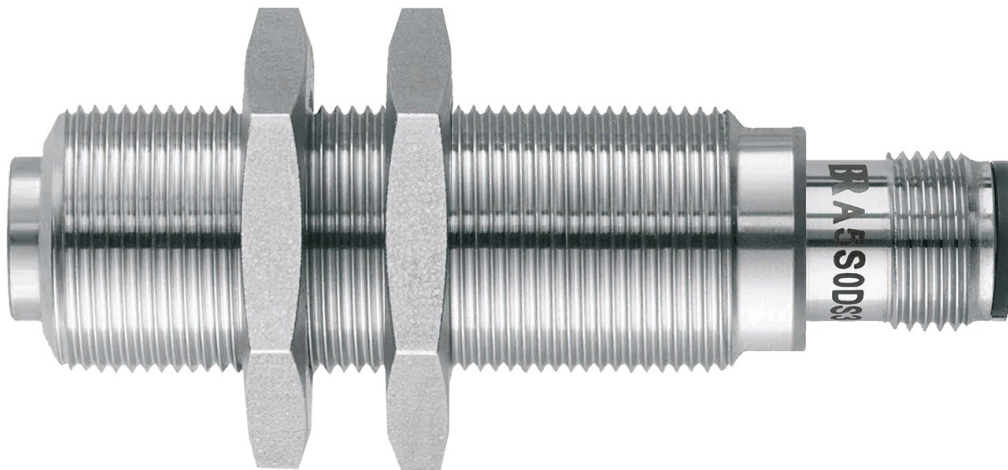

A5S view
(version A5S0DS0M2210B48 shown)

Speed Sensors based on Differential-Hall-Effect Principle

TÜV certified for IEC 61508:2010; SIL 3

EN ISO 13849-1:2015; PL e; Cat. 4

EN ISO 13849-2:2012; PL e; Cat. 4

IEC 62061:2021; SIL_{CL} 3

Table of Contents

Contents	Page
Table of Contents	2
1 General Information	3
1.1 List of Figures.....	3
1.2 List of Abbreviations.....	4
1.3 Application characteristics.....	5
1.4 Mounting of the Sensor.....	5
1.4.1 Notes on Pole Wheel.....	6
1.4.2 Positioning of Sensor.....	6
1.4.2.1 Alignment of Sensor.....	6
1.4.2.2 Recommended Air Gap.....	7
1.4.3 Maximum fastening torques / wrench sizes / thickness of BRAUN nuts.....	7
1.5 Connection (pin assignment resp. wire assignment).....	8
1.6 Arrangement of Pins in Sensor Plug.....	8
1.7 Signal Transmission.....	9
1.8 Direction of rotation signal for sensor series A5S0DD3 / A5S0DS3 / A5S3.....	10
1.9 Speed signal f2 (phase-shifted) for sensor series A5S0DD4 / A5S0DS4 / A5S4.....	10
1.10 Level and shape of the output signal.....	11
1.11 Ordering Key for Sensors of A5S0... Series.....	12
1.11.1 Ordering Key old / current.....	13
1.12 Safety Data.....	14
1.13 Certification.....	14
1.13.1 Certification IEC 61508:2010; SIL 3.....	14
1.13.2 Certification EN ISO 13849-1:2015; PL _e ; Cat. 4.....	14
1.13.3 Certification EN ISO 13849-2:2012; PL _e ; Cat. 4.....	14
1.13.4 Certification IEC 62061:2021; SIL _{CL} 3.....	14
1.13.5 SIL 3 Certificate.....	15
2 This chapter is left blank intentionally	16
3 Safety Notes for Installation and Operation	16
3.1 General Instructions.....	16
3.2 EMI.....	16
3.3 Safety note about metallic abrasion in the machine.....	16
3.4 Safety Notes on Installation.....	16
3.4.1 Initial Commissioning and Installation.....	16
3.5 Safety Notes on Operation.....	16
3.5.1 Machine Maintenance or Overhaul.....	16
4 Technical Specifications	17
4.1 Conformity to Standards.....	17
4.2 Power Supply.....	17
4.3 Signal Output.....	17
4.4 Speed (Frequency-) Range.....	17
4.5 Recommended cable type for long cable lengths.....	17
4.6 Electrical Protective Measures.....	17
4.7 Connection.....	17
4.8 Permissible Ambient Temperature.....	17
4.9 Installation Dimensions.....	17
4.10 Cable diameters of BRAUN Cables.....	18
4.11 Weight.....	18
4.12 Vibration and Shock Immunity.....	18

5	Accessories (optional).....	18
6	Useful Lifetime, Proof Test Interval and replacement of A5S sensors	18
7	Dimensions at different Connection Types.....	19
8	Revision Notes	20

1 General Information

1.1 List of Figures

Figure 1:	Adjustment to the profile edges	5
Figure 2:	Alignment of sensor	6
Figure 3:	Information on profile size.....	7
Figure 4:	SIL 3 Certificate	15
Figure 5:	Dimensions at different connection types	19

1.2 List of Abbreviations

Abbreviation	Meaning
altern.	alternative
API	Technical standards of the "American Petroleum Institute"
A5S	BRAUN GmbH Sensor series
DIN	German Institute for Standardisation (Deutsches Institut für Normung)
EMC	Electro magnetic compatibility
EN	European Norm
IEC	International Electrotechnical Commission
incl.	inclusive
IPxx	Ingress Protection Number xx according to DIN EN 60529
ISO	International Organization for Standardization
max.	maximum
min.	minimum
MTTFd	Mean Time To Failure dangerous
n	Short term for Speed
NEMAx	National Electrical Manufacturers Association Number x
Nm	Newton meter
PELV	Protective Extra Low Voltage
PFDavg	Probability of Failure on Demand average
RPM	Revolutions Per Minute
sec	second
SELV	Safety Extra Low Voltage
SILx	Safety Integrity Level x
TMR	Triple Modular Redundant
Ub	+ supply voltage
UL	Underwriter Laboratories
Vdc or V dc	Volt direct current
F/R	Forward/Reverse (Forward/Backward)

1.3 Application characteristics

Speed sensors for applications such as turbines, compressors, expanders etc. in non-hazardous areas. Safety classification up to SIL 3 / IEC 61508:2010 resp. EN ISO 13849-1:2015 PL e Kat. 4, EN ISO 13849-2:2012 PL e Kat. 4 and IEC 62061:2021; useable in applications up to SIL_{CL} 3 as speed sensors.

Their low end of 0 Hz allows monitoring the machine down to zero speed. They are contact-free, wear-free, maintenance-free and unsusceptible versus external magnetic stray fields and machine vibration.

Sensors A5S0DD0 and A5S0DS0 and A5S0 for detection of rotational speed

Single Channel, the output provides the rotational speed as a single-track frequency signal.

Sensors A5S0DD3 and A5S0DS3 and A5S3 for detection of rotational speed and direction of rotation

Dual Channel, 1 track = rotational speed as frequency, 1 track = F/R status as binary signal.

Sensors A5S0DD4 and A5S0DS4 and A5S4 for detection of rotational speed and direction of rotation with two phase-shifted speed signals

Dual Channel, the output provides the rotational speed as a twin-track frequency signal (phase shifted). Suitable for external direction detection with enhanced safety.

1.4 Mounting of the Sensor

The sensor should be mounted in radial direction so that it points to the axis of rotation of the rotating profile. An arrangement parallel to the axis of rotation for frontal scanning is also possible. Then, a possible axial displacement in the machine must be considered. All our information applies to radial scanning.

For mounting, it is best to have the same thread in the fixed part. The sensor is then fixed in the correct position with the supplied nut.

The mounting may be made flush in any material; several sensors can also be placed close to each other.

A solid and vibration-free mounting of the sensor is important.

Adjustment to the profile edges

Mounting preferably in radial direction and in alignment with the profile

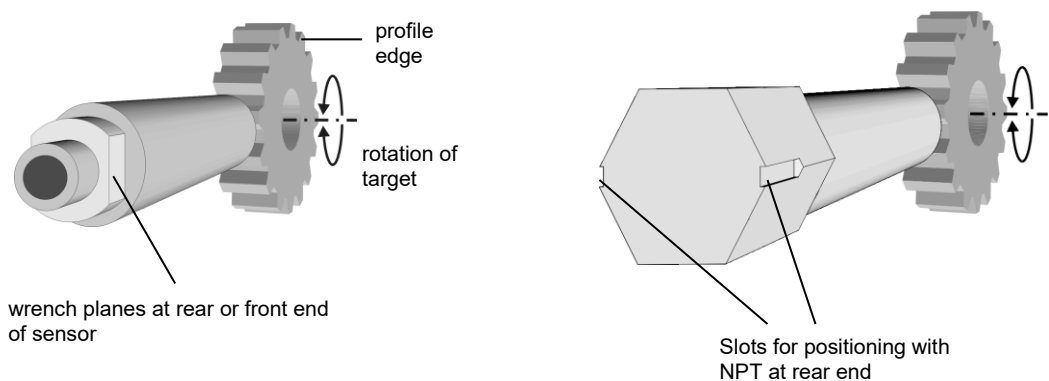

Figure 1: Adjustment to the profile edges

1.4.1 Notes on Pole Wheel

The pole wheel must be made of ferromagnetic steel. Non-ferrous material, stainless steel or plastics do not work.

The grooves / bolts of the pole wheel must be equidistant; otherwise the speed signal will be unsteady.

The pole wheel should have no damage or burrs; otherwise the speed signal can become unsteady. If there is any damage, increasing the gap in the air can eliminate a possible fault (double pulses).

1.4.2 Positioning of Sensor

1.4.2.1 Alignment of Sensor

The sensor must be aligned with the flanks of the profile to be scanned. It is correctly installed if the two planes at the end of the sensor (which also serve as wrench planes for screwing in) point in the direction of the profile or perpendicular to the profile edges (for example the tooth flanks of a gear).

A deviation of up to $\pm 20^\circ$ is permitted.

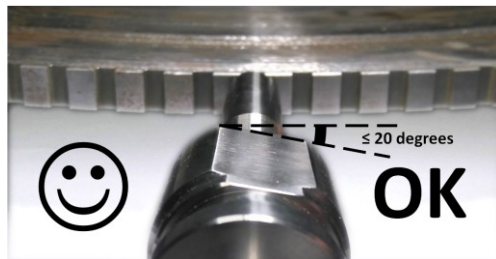

Correct alignment of the sensor

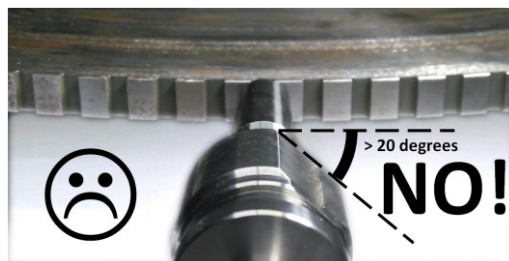
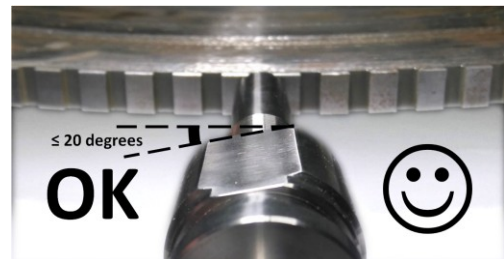

Incorrect alignment of the sensor

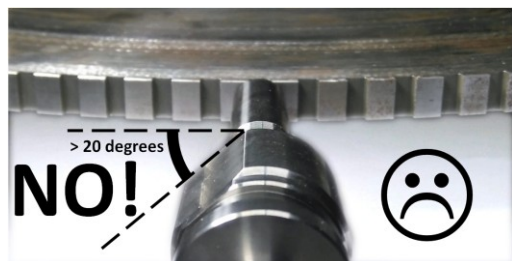
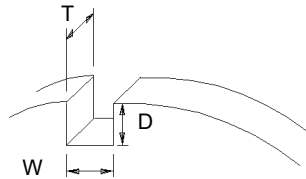

Figure 2: Alignment of sensor

1.4.2.2 Recommended Air Gap

The recommended air gap between the sensor front surface and the rotating part must be observed. It increases with the size of the profile: For cams or milled grooves with their width, distance and depth, for a gear with its module (= diameter / number of teeth). The field between grooves or cams must be at least as large as the specified width (W), the depth D = at least 3 mm. Thickness of a gear or length (T) of a milled recess of at least 5 mm (plus a possible axial displacement).

The guideline values given below for the profile size (D / W / T) of a rotor are the minimum dimensions, they may be exceeded in any direction. However, the maximum permissible air gap between the sensor and the pole wheel will not increase.



Profile size of a grooved wheel

D = min. 3 mm
W = min. 3 mm
T = min. 5 mm

Figure 3: Information on profile size

Air gap in dependency of profile size			A5S0DS0 A5S0DD0 A5S05...A5S09	A5S0DS3 and DS4 A5S0DD3 and DD4 A5S3... and A5S4...
Module of a gear wheel	Diametrical Pitch approx.	min. width W of a groove wheel	Recommended air gap	Recommended air gap
m1	25.40 mm	3 mm	0.5 – 0.8 mm	--
m1.5	16.93 mm	3 mm	0.5 – 1.0 mm	--
m2	12.70 mm	3 mm	0.8 – 1.5 mm	0.3 – 0.8 mm
m3	8.47 mm	3 mm	0.8 – 2.0 mm	0.3 – 1.2 mm
m4	6.35 mm	3 mm	1.0 – 2.5 mm	0.5 – 1.5 mm

1.4.3 Maximum fastening torques / wrench sizes / thickness of BRAUN nuts

Nut	Maximum fastening torque	wrench size	thickness (+/- 0.5 mm)
M12 x 1	12 Nm	WS 19	6 mm
M14 x 1	25 Nm	WS 22	4 mm
M14 x 1.5	25 Nm	WS 22	7 mm
3/4"-16	25 Nm	WS 28	10 mm
M16 x 1	35 Nm	WS 24	8 mm
M18 x 1	50 Nm	WS 26	9 mm
3/4"-20	50 Nm	WS 24	6 mm
M18 x 1.5	50 Nm	WS 26	9 mm
5/8"-18	50 Nm	WS 24	10 mm
M22 x 1	75 Nm	WS 30	6 mm

1.5 Connection (pin assignment resp. wire assignment)

All sensors described here can have different dimensions and different connection types.

For the connections applies to the different types:

Assignment	with plug pin no.	with open cable ends of BRAUN cables wire color
Signal output 1: (speed signal f1)	4	white
Common zero	3	green
+ sensor supply U_b	1	brown
Signal output 2: (speed signal f2 resp. rotation direction signal)	2	red (at Teflon® cable) resp. yellow (at PVC cable)
Screen (not connected to sensor housing)		black

1.6 Arrangement of Pins in Sensor Plug

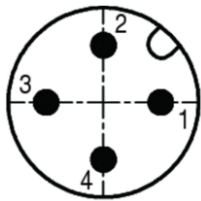

The M12 connector uses the A-coding (DIN EN 61076-2-101).

The possible transmission distance is essentially determined by the highest occurring signal frequency, the properties of the transmission line and the input of the connected receiving device.

When connected to our equipment for fixed installation, a signal frequency of 25000 Hz can be safely transmitted over a distance of up to 500 m. If the signal frequency is lower, a correspondingly longer transmission distance applies. The cable is based on a 3-core or 4-core shielded version LiYCY or LiTCT with $3 \times 0.5 \text{ mm}^2$ or $4 \times 0.5 \text{ mm}^2$, as supplied by us ($R < 36 \text{ Ohm / km}$, $C < 150 \text{ pF / m}$).

The signal frequency in Hz is calculated with a uniformly divided profile by:

Number of poles x speed / 60.

For narrow poles, the effective frequency must be set higher in accordance with the relationship between pole and gap.

Important in the transmission:

A continuous good shielding must be provided. The shield must be connected directly to a shield rail on the receiving side. Never transmit multiple signals under one common screen! Lay transmission line separately from sources of interference.

1.8 Direction of rotation signal for sensor series A5S0DD3 / A5S0DS3 / A5S3

The sensor indicates the direction of rotation by a constant signal, which is either high or low depending on the direction (see below for level values). The change is instantaneous as soon as a pole pitch (e.g., 1 tooth) has passed the sensor. At standstill, the last reported direction is retained. A hysteresis in the direction change or the combination with a speed lower limit must be implemented in the connected evaluation unit.

The assignment between the signal level and the direction of rotation results from the installation position of the sensor. For the purpose of predetermination, a mark \circ is placed on the type strip of the sensor. If the profile wheel rotates clockwise in the viewing direction to this mark, the output has high level, otherwise low level.

Relationship between mark and direction signal

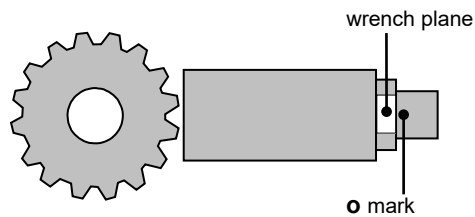

\circ mark visible and rotation in clockwise direction = direction output high

\circ mark visible and rotation in counterclockwise direction = direction output low

\circ mark not visible: output inverse to above

1.9 Speed signal f2 (phase-shifted) for sensor series A5S0DD4 / A5S0DS4 / A5S4

The sensor provides two phase-shifted frequency signals f1 and f2:

Relationship between mark and phase position

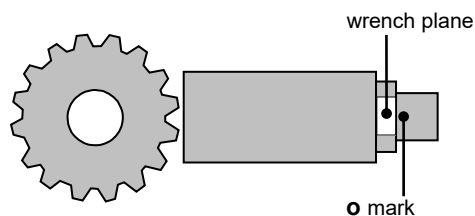

\circ mark visible and rotation in clockwise direction: f1 is ahead

\circ mark visible and rotation in counterclockwise direction: f2 is ahead

\circ mark not visible: phase position inverse to above

1.10 Level and shape of the output signal

Rectangular pulses at low frequencies and with short lines. At higher frequencies and with long lines, the signal at the receiver becomes a saw tooth tread profile.

Pulse pitch depends on the profile shape, when sampling a gear wheel profile, it is about 1:1. The level is the same over the entire speed range. The built-in output stage can pull loads to zero and to operating voltage equally strong.

The signal level during no-load running is almost equal to the supply voltage. The diagrams show how it gets smaller when the current load increases (the high-level decreases, the low level becomes higher). If the permissible maximum load of 25 mA is exceeded, the level drops sharply. The sensor is not damaged, the output is short-circuit proof.

The maximum load corresponds to a load resistance of 1000 ohms at 24 V supply voltage, 500 ohms are permissible with 12 V supply voltage.

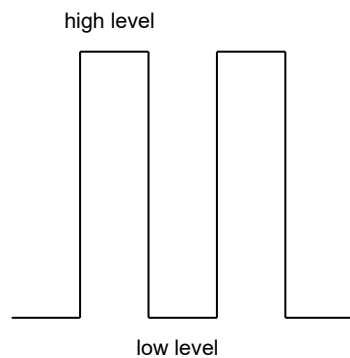

Output level with load against zero

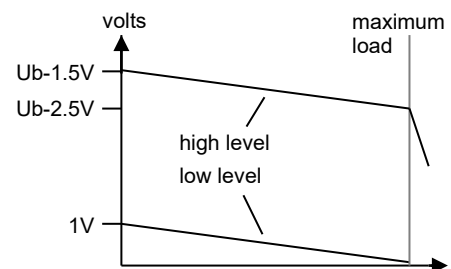
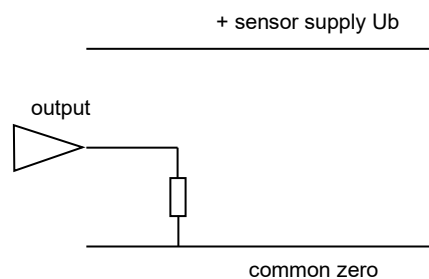

Output level with load against Ub (+ supply)

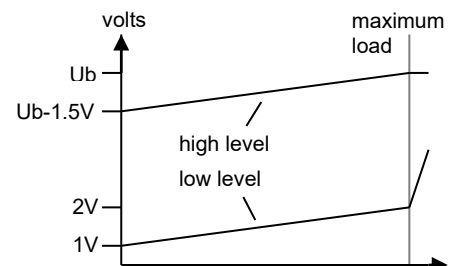
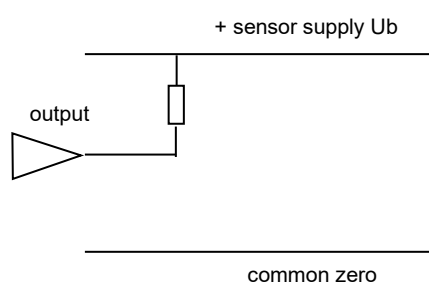

A5S0		b	c	d	e	f	g	-xm
Signal frequency								Length of fixed Teflon® cable in m*
b = DD : 0 Hz...25 kHz								Standard lengths for cable:
b = DS : 0 Hz...12 kHz								x = 2, 5, 8, 10, 15, 20
								*(omit for versions with screw-plug-in connection)
Signal output								Nominal thread length in mm
c = 0 : 1x frequency								Standard length for thread:
c = 3 : 1x frequency / 1x direction*								g = 50, 120 : M12x1 (1210)
c = 4 : 2x frequency, phase-shifted*								g = 80 (if f = T) : M12x1 (1210)
*minimum nominal thread length 74 mm								g = 90 (if f = B) : M12x1 (1210)
								g = 50, 90, 154 : M14x1 (1410)
								g = 50, 90, 154 : M14x1.5 (1415)
								g = 48 : M16x1 (1610)
								g = 80, 154 : M16x1.5 (1615)
								g = 48, 94 : M18x1 (1810)
								g = 50, 74, 94 : M18x1.5 (1815)
								g = 48, 94 : M22x1 (2210)
								g = 90 : 3/4"-16 (3416)
								g = 90 : 3/4"-20 (3420)
								g = 48, 100, 165 : 5/8"-18 (5818)
								other lengths on request
Unit of shaft diameter								Connection type
d = M : metric								f = B : screw-plug-in connection
d = N : inch and ½-NPT at end of sensor								f = T : fixed Teflon® cable
d = U : inch								
Thread of shaft diameter								
Standard thread:								
e = 1210 : M12x1 (metric)								
e = 1410 : M14x1 (metric)								
e = 1415 : M14x1.5 (metric)								
e = 1610 : M16x1 (metric)								
e = 1615 : M16x1.5 (metric)								
e = 1810 : M18x1 (metric)								
e = 1815 : M18x1.5 (metric)								
e = 2210 : M22x1 (metric)								
e = 3416 : 3/4"-16 (inch)								
e = 3420 : 3/4"-20 (inch)								
e = 5818 : 5/8"-18 (inch)								
other threads or flat shafts on request								

Examples:

- A5S0DD0M1210B120 = Signal frequency up to 25 kHz, signal output 1x frequency, thread M12x1, screw-plug-in connection, nominal length 120 mm
- A5S0DS0M1415B90 = Signal frequency up to 12 kHz, signal output 1x frequency, thread M14x1.5, screw-plug-in connection, nominal length 90 mm
- A5S0DD3M1615T80-5m = Signal frequency up to 25 kHz, signal output 1x frequency / 1x direction, thread M16x1.5, Teflon® cable with 5m length, nominal length 80 mm
- A5S0DS3M2210T94-5m = Signal frequency up to 12 kHz, signal output 1x frequency / 1x direction, thread M22x1, Teflon® cable with 5m length, nominal length 94 mm
- A5S0DD4U5818B100 = Signal frequency up to 25 kHz, signal output 2x frequency (phase shifted), thread UNF5/8-18, screw-plug-in connection, nominal length 100 mm
- A5S0DS4M1815T94-2m = Signal frequency up to 12 kHz, signal output 2x frequency (phase shifted), thread M18x1.5, Teflon® cable with 2m length, nominal length 94 mm

1.11.1 Ordering Key old / current

The following table is used to better allocate the old and current ordering keys.

Old standard ordering keys	Corresponding current ordering keys
A5S05...	A5S0DS0M1415...
A5S07...	A5S0DS0M1210...
A5S08...	A5S0DS0M1810...
A5S08...A	A5S0DS0U5818...
A5S08...C	A5S0DS0N5818...
A5S09	A5S0DS0M2210...
A5S30...	A5S0DD3M1810...
A5S31...	A5S0DD3M1415...
A5S32...	A5S0DD3M2210...
A5S33...	A5S0DD3M1210...
A5S40...	A5S0DD4M1810...
A5S41...	A5S0DD4M1415...
A5S42...	A5S0DD4M2210...
A5S43...	A5S0DD4M1210...

1.12 Safety Data

See A5S-SIL-Datasheet.

1.13 Certification

1.13.1 Certification IEC 61508:2010; SIL 3

The A5S... series differential hall effect sensors are TÜV certified according to IEC 61508:2010; suitable up to SIL3 as stand-alone speed sensors for the functions:

- speed monitoring in connection with BRAUN E16 machine protection systems
- output of a correct speed signal (frequency) with an accuracy of +/- 1Hz

1.13.2 Certification EN ISO 13849-1:2015; PLe; Cat. 4

The A5S... series differential hall effect sensors are TÜV certified according to EN ISO 13849-1:2015; suitable up to PLe; Cat. 4 as stand-alone speed sensors for the functions:

- speed monitoring in connection with BRAUN E16 machine protection systems
- output of a correct speed signal (frequency) with an accuracy of +/- 1Hz

1.13.3 Certification EN ISO 13849-2:2012; PLe; Cat. 4

The A5S... series differential hall effect sensors are TÜV certified according to EN ISO 13849-2:2012; suitable up to PLe; Cat. 4 as stand-alone speed sensors for the functions:

- speed monitoring in connection with BRAUN E16 machine protection systems
- output of a correct speed signal (frequency) with an accuracy of +/- 1Hz

1.13.4 Certification IEC 62061:2021; SIL_{CL} 3

The A5S... series differential hall effect sensors are TÜV certified according to IEC 62061:2021; suitable in applications up to SIL_{CL} 3 as stand-alone speed sensors for the functions:

- speed monitoring in connection with BRAUN E16 machine protection systems
- output of a correct speed signal (frequency) with an accuracy of +/- 1Hz





Certificate

No. SEBS-A.095133/15, V2.0

TÜV NORD Systems GmbH & Co. KG hereby certifies to

Braun GmbH
Esslinger Straße 26
71334 Waiblingen-Hegnach

that the Differential-Hall-Effect based Sensor
Type Series A5S

meets the requirements
listed in the below mentioned standards by external diagnostic

- IEC 61508:2010 (capable up to SIL 3)
- EN ISO 13849-1:2015 (capable up to PL e; Cat. 4)
- EN ISO 13849-2:2012 (capable up to PL e; Cat. 4)
- IEC 62061:2021 (capable for applications up to SIL 3)

Certification program Leittechnik (SEB-ZE-SEECERT-VA-320-20, Rev. 5.1/04.19)

Base of certification is the report SEBS-A.095133/15TB and the tracking list in the valid version.

This certificate entitles the holder to use the pictured safety approved mark.

Valid until: 08-12-2026
File reference: 8119303478

Hamburg, 08-12-2021

Bianca Pfuff



Certification body SEECERT
 TÜV NORD Systems GmbH & Co. KG
 Große Bahnstraße 31, 22525 Hamburg, Germany

Figure 4: SIL 3 Certificate

2 This chapter is left blank intentionally

3 Safety Notes for Installation and Operation

3.1 General Instructions

The sensors of series A5S0... are built and tested according to standards DIN EN 61010-1 (VDE 0411-1) and have left the factory in a perfectly safe condition. To maintain this condition and to ensure safe operation, the user must follow the instructions contained in this manual. Connection and maintenance work may only be performed by adequately qualified personnel and only when the power supply is switched off.

Important:

If the safety instructions are not followed, it is possible that the sensor will not deliver a speed signal !!!

3.2 EMI

The sensor complies with all relevant regulations, as determined by the Policy of the European Committee for Electrotechnical Standardization (CENELEC), for the Electromagnetic Compatibility (2014/30/EU). Testing and inspection have been performed according to Standards EN 61326-1 and EN 61326-3-2. Thereby, the product meets all requirements to be marked by the CE sign.

For space reasons, the sensor is marked by its model No. but does not carry the CE-mark.

3.3 Safety note about metallic abrasion in the machine

Metallic (ferromagnetic) abrasion may adhere to the front of the sensors when the machine is at standstill. It must be ensured by appropriate measures (oil filter, if the sensors are mounted in oil or mounting the sensors on the top of the machine) that this does not happen.

Otherwise it is possible that the sensor will not provide a speed signal when the machine restarts.

In general, the circulation of the oil or the air draft when starting the machine removes the metal abrasion from the sensor. Subsequently, the sensor must be recalibrated by switching off and on its power supply.

3.4 Safety Notes on Installation

3.4.1 Initial Commissioning and Installation

After the sensor has been mounted and the air gap checked, the sensor must be recalibrated to the current air gap.

The sensor is recalibrated by switching off and on its power supply.

3.5 Safety Notes on Operation

Chapter 3.3 has to be observed, too.

3.5.1 Machine Maintenance or Overhaul

If the air gap has been changed or the air gap has been checked, e.g. with a feeler gauge, the sensor must be recalibrated to the current air gap.

The sensor is recalibrated by switching off and on its power supply.

4 Technical Specifications

4.1 Conformity to Standards

EU-Directive(s)	Standard(s)
2014/30/EU EMC directive	EN 61326-1, EN IEC 61326-3-2
2014/35/EU Low voltage directive	EN 61010-1
2011/65/EU RoHS directive	EN IEC 63000

4.2 Power Supply

Supply voltage: + 6 V... + 30 V DC.
Current consumption: approx. 15 mA (one channel sensor) resp. 25 mA (two channel sensor), plus load (can increase up to 60 mA with long transmission length and high signal frequency).
If power supply isn't provided by a BRAUN device, a PELV resp. SELV power supply has to be used.

4.3 Signal Output

Rectangular pulses with constant high level and low level over the entire speed range.
Push-Pull amplified output. Maximum load 20 mA.
The signal output is short circuit proof and protected against polarity error.

4.4 Speed (Frequency-) Range

Speeds with a maximum signal frequency of:
A5S0DS: 0 Hz...12 kHz
A5S0DD: 0 Hz...25 kHz

4.5 Recommended cable type for long cable lengths

Cable in shielded version LIYCY with 3x0.5 mm², resp. 4x0.5 mm² with R < 36 Ohm/km and C < 150 pF/m).

4.6 Electrical Protective Measures

Protection class: no protection needed
IP code: IP67, pressure-tight stainless-steel housing (1.4305)

4.7 Connection

Connection with screw-plug-in connection (straight or angled) or with fixed Teflon® (up to 125°C) cable.

4.8 Permissible Ambient Temperature

for the front part of the sensor: -40°C...+125°C
with plug-in connection: -40°C... +85°C
with fixed Teflon® cable: -40°C...+125°C

4.9 Installation Dimensions

The sensors are available with different installation threads (D) metric, resp. inch, resp. inch with NPT, and each with a number of different nominal lengths (L). This is the length from the front surface of the sensor to the end of the mounting thread (see figures on next page).

4.10 Cable diameters of BRAUN Cables

L3A: PVC 3-wire (LiYCY 3x0.5 mm²) : approx. 5.4 mm (+/- 0.5 mm)
L4A: PVC 4-wire (LiYCY 4x0.5 mm²) : approx. 5.8 mm (+/- 0.5 mm)
L3T: Teflon® 3-wire (LiTCT 3x0.34 mm²) : approx. 4.6 mm (+/- 0.5 mm)
L4T: Teflon® 4-wire (LiTCT 4x0.34 mm²) : approx. 4.6 mm (+/- 0.5 mm)

4.11 Weight

The weight depends on the length and shaft diameter of the sensor and the length of fixed cables.

4.12 Vibration and Shock Immunity

Vibration immunity: 5 g_n in the range 5...2000 Hz
Shock immunity: 20 g during 20 ms, half-sine wave

5 Accessories (optional)

Cable with connector:

L3A22BO-xm:

PVC sensor connection cable (3-wire) with straight plastic connector

L3A23BO-xm:

PVC sensor connection cable (3-wire) with angled plastic connector

L3T24MO-xm:

Teflon® sensor connection cable (3-wire) with straight metal connector

L3T25MO-xm:

Teflon® sensor connection cable (3-wire) with angled metal connector

L4A08BO-xm:

PVC sensor connection cable (4-wire) with straight plastic connector

L4A06BO-xm:

PVC sensor connection cable (4-wire) with angled plastic connector

L4T09MO-xm:

Teflon® sensor connection cable (4-wire) with straight metal connector

L4T10MO-xm:

Teflon® sensor connection cable (4-wire) with angled metal connector

x = cable length in meters

Only connector:

Bi4F/01: straight connector (plastic body)

Bi4F/02: angled connector (plastic body)

Bi4F/05: straight connector (metal body)

Bi4F/04: angled connector (metal body)

6 Useful Lifetime, Proof Test Interval and replacement of A5S sensors

The Useful Life Time of A5S... sensors are 20 years.

The Proof Test Interval of A5S... sensors are 20 years.

The A5S... sensors are maintenance free in principle and only need replacement if a fault occurs.

The normal lifetime of A5S sensors (by design, but not guaranteed) at operation temperatures up to 60 °C is 20 years.

At higher operation temperatures or if the availability is crucial, we suggest a replacement of the sensors after 5 years of operation during a normal revision of the machine.

7

Dimensions at different Connection Types

Sensor with screwed on straight mating connector Bi4F/05 resp. cable L3T24MO-xm resp. cable L4T09MO-xm

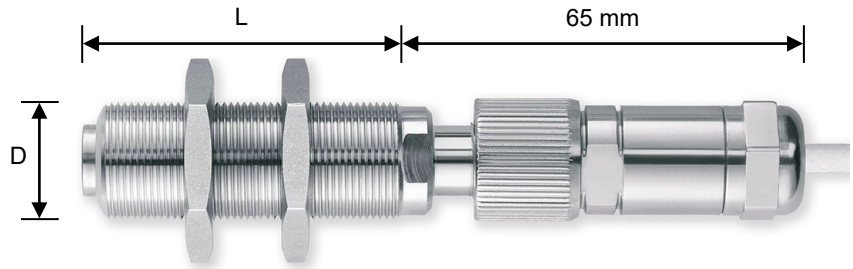

Sensor with screwed on angled mating connector Bi4F/04 resp. cable L3T25MO-xm resp. cable L4T10MO-xm

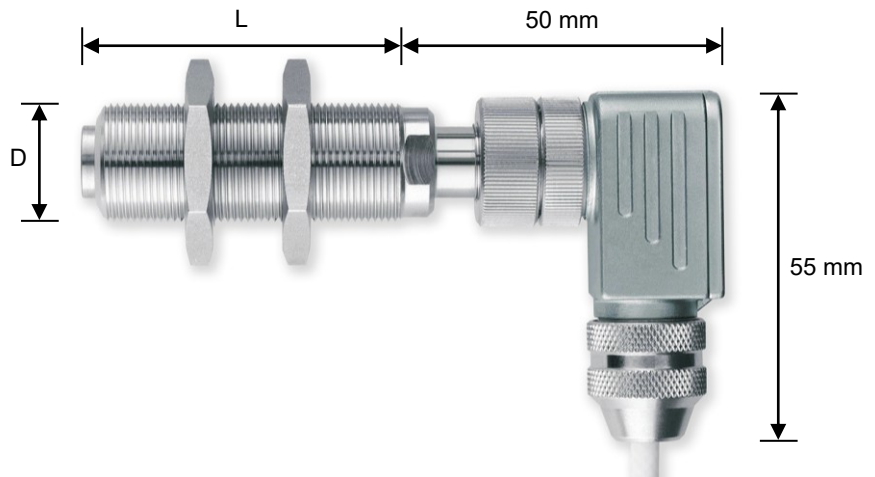

Sensor with fix mounted connecting Teflon® cable

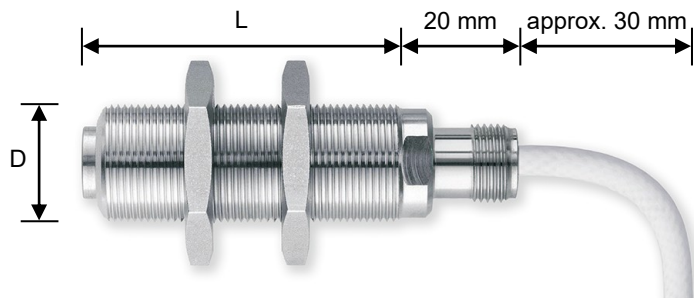

Sensor (NPT version) with fixed Teflon® cable, only for 5/8"-18 (inch) thread

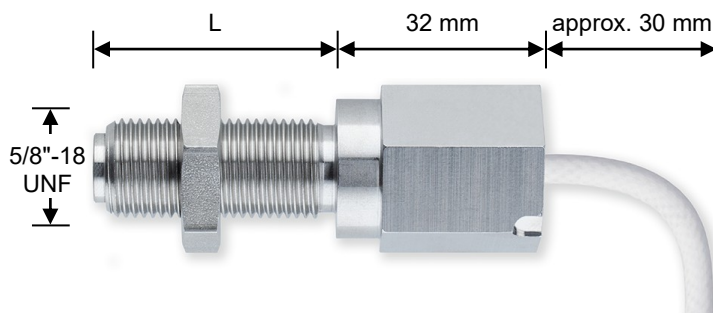

Also see chapter 1.11 (Ordering keys for available shaft diameters D and nominal lengths L)

Figure 5: Dimensions at different connection types

Date	Rev.	Modification
13.08.2018	00	First edition
13.08.2018	01	Adjustment of revision no. to match German version
07.12.2018	01	Editorial: Chapter 7: Thread diameter for NPT-Version inserted.
25.02.2019	01	Editorial: New Chapter 1.11.1 inserted.
18.03.2019	01	Editorial: Chapter 1.11: additional standard threads and nominal lengths inserted.
17.04.2019	01	Editorial: Chapter 1.4.3: additional values for threads 3/4"-16 and 3/4"-20 inserted.
19.01.2021	01	Editorial: Chapter 4.1: standards adapted.
29.06.2021	01	Editorial: Chapter 1.11 adapted.
13.10.2021	01	Editorial: New Chapter 4.12 inserted.
08.12.2021	01	Editorial: New SIL3 certificate added to chapter 1.13.5 and standards adapted. Addition in chapter 1.6.
07.05.2024	02	Technical: Chapter 1.11: Thread M12x1 with nominal length of 80 mm and screw-plug-in connection (f = B) is obsolete and replaced by nominal length of 90 mm.
27.11.2024	03	Editorial: Connector and cable designations added to the dimensions in chapters 4.10 and 7.



Protecting Your Rotating Equipment

D 71334 Waiblingen-Hegnach
Esslinger Str. 26
Phone: +49 (0)7151/956230
E-Mail: info@braun-tacho.de
Internet: www.braun-tacho.de