

**D225.11** (with RS232-Interface) resp. D224.11S2  
**D225.12** (with PROFIBUS-Interface) resp. D224.12S2

## Speed and Direction Monitor with sensor monitoring

Datasheet and Manual

Note: This manual is also valid for Monitors D224.11S2 resp. D224.12S2 (which are identical in construction)

Contents	page
<b>Specifications</b> .....	2
<b>Key Features</b>	
Functions.....	3
Front View and Controls.....	3
Display .....	3
Event Codes in Display .....	3
<b>Notes for Installation and Operation</b>	
Safety Notes for Installation .....	4
Initial values of Parameters .....	4
General Instructions .....	4
Power Supply and EMI.....	4
Wiring diagram with sensor A5S with Frequency/Reverse Signal (F/R).....	5
Wiring diagram with sensor A5S with two Frequency Signals (F/F).....	6
Dimensions .....	7
<b>Programming</b>	
Summary of programming steps .....	8
Detailed description of programming steps .....	10
<b>Programming of the D225.11 via RS232-Interface</b> .....	19
<b>Programming of the D225.12 via PROFIBUS-Interface</b> .....	19

### Revision Notes:

Rev03\_2018\_03\_20:

P01.10 = 001 (predivider is obsolete)

P03.04 = 1 (voltage analog output is obsolete)

Standards are adjusted to actual releases

Rev03\_2018\_03\_21: Misspelling corrected

Rev04\_2024\_JUL\_23: Note for D224.11S2 resp. D224.12S2 added



## Key Features

### Functions

The monitor has in conjunction with the speed sensors A5S the functions:

- speed monitoring,
- direction alarm output,
- three speed alarm outputs (can be changed to direction alarm),
- analog output of speed,
- sensor monitoring,
- data interface RS232 (with D225.11) or PROFIBUS (with D225.12).

### Front View and Controls

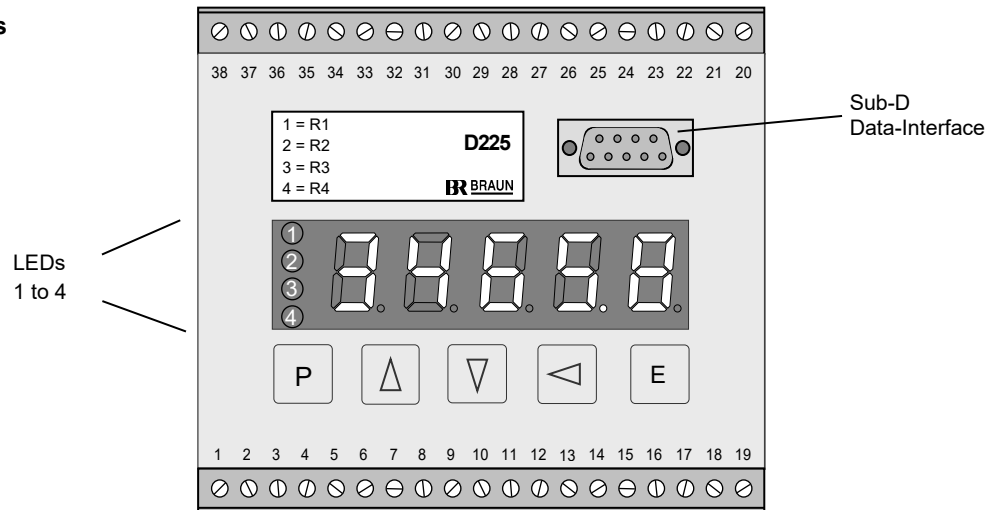

### Display

In normal operation the display reads the speed.

LED1 is on if Relay 1 (SP1) is energized.

LED2 is on if Relay 2 (SP2) is energized.

LED3 is on if Relay 3 (SP3) is energized.

LED4 is on if Relay 4 (SP4) is energized.

Display in  
normal operation

Display of maximum / minimum measured speed:

Display max.- speed, while key is pressed,

Display min.- speed, while key is pressed.

clear max. / min.-value with key .

Maximum /  
Minimum

### Event Codes in Display

-E1- : unauthorized access with incorrect code No.

SE-01 : Sensor current fault

SE-02 : Sensor level fault input I

SE-20 : Sensor level fault input II

SE-40 : Sensor fault detected

Event Codes

Resp. combinations hereof, for example

SE-22 : Sensor level fault input I and II

## Notes for Installation and Operation

### Safety Notes for Installation

The unit complies with all relevant regulations, as determined by the Policy of the European Committee for Standardization (CEN), for the Low Voltage Directive (2014/35/EU).

Testing and inspection have been performed according to standard DIN EN 61010-1. Observe these instructions and wiring diagrams carefully, to ensure this protection. The installation must only be done by adequately qualified personnel.

Safety Notes

### Initial Parameter Values

Each unit is delivered with initial parameter values. These values must be adjusted to the application.

Initial Parameter Values

### General Instructions

Specifically, connect the ground terminal of the instrument to a safe ground potential.

Do not open the instrument. Connections and all programming are done from outside. When removing it from its enclosure however, from whatever reason, make sure that power is switched off.

The instrument may be installed in any position, but not in the immediate neighborhood of interfering sources.

Signal leads must be carefully shielded, and should not be run in bundles with power or relay control leads.

The ground terminal (PE) is internally separated from common zero, but tied by a 82 k resistor to it.

### Power Supply and EMI

The unit complies with all relevant regulations, as determined by the Policy of the European Committee for Electrotechnical Standardization (CENELEC), for the Electromagnetic Compatibility (2014/30/EU).

Testing and inspection have been performed according to Standards EN 61326-1 and EN 61326-3-2. Thereby, the product meets all requirements to be marked by the CE sign.

Strict observance of these instructions during installation and use is an indispensable precondition hereto.

Specifically to be observed:

Terminals must be kept off all undue access; power supply and all input and output leads must be protected against voltage interference, higher than specified operation data, and they must be protected against electrostatic discharge.

Power Supply and EMI

**Wiring diagram  
for sensors A5S with Frequency and Reverse Direction Signal (F/R)**

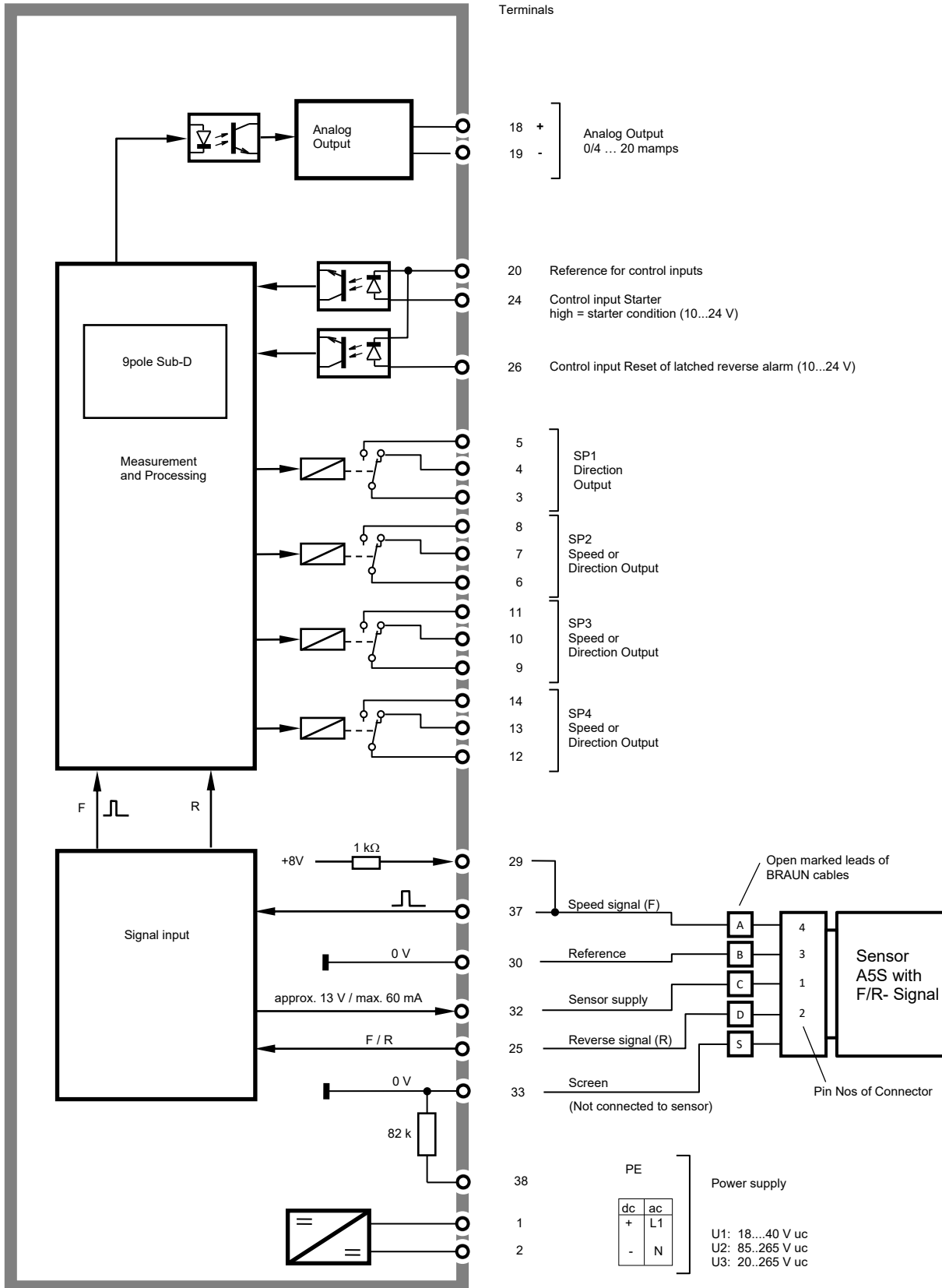

**Wiring diagram  
for sensors A5S with two Frequency Signals (F/F)**

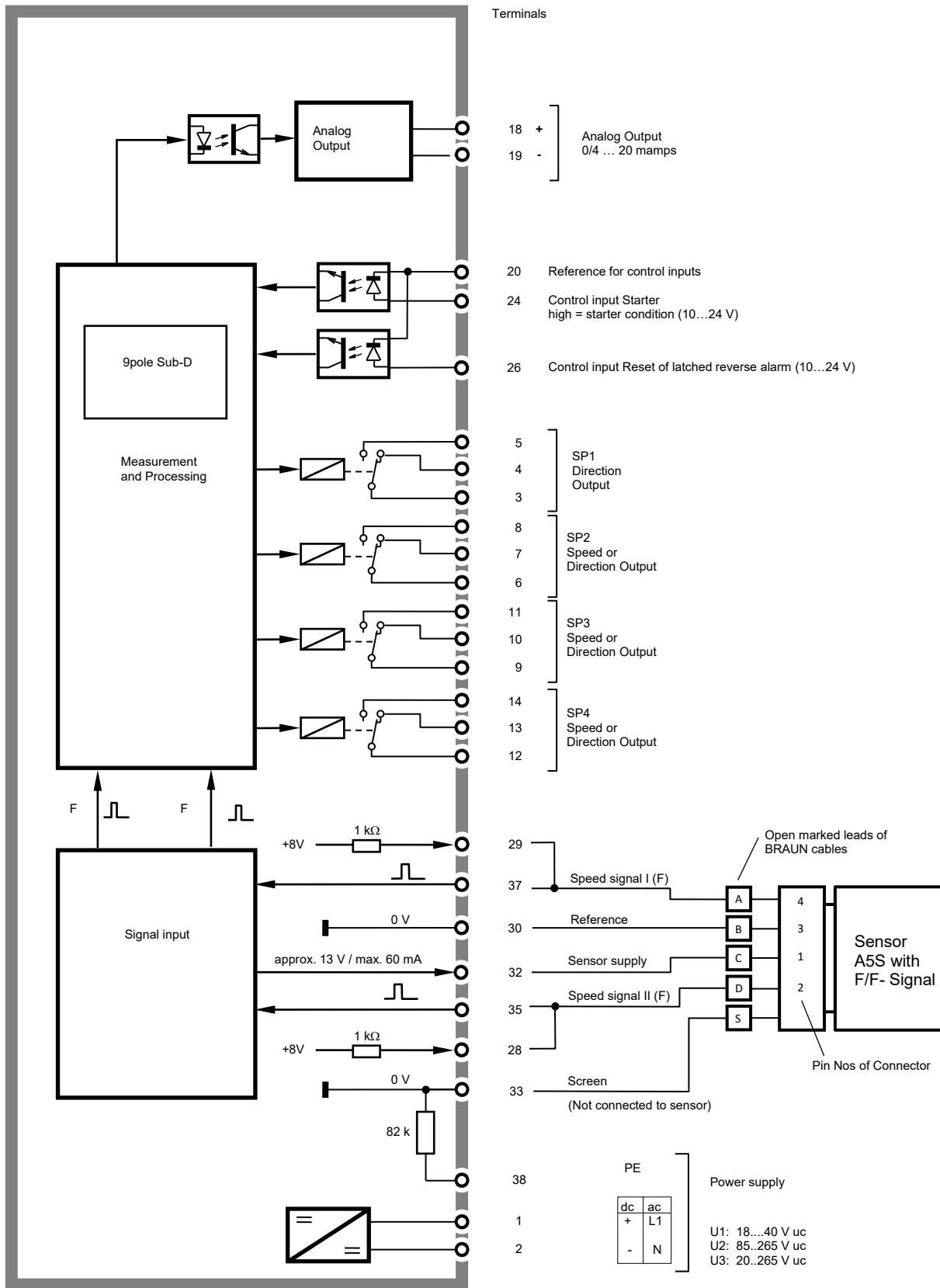

## Dimensions

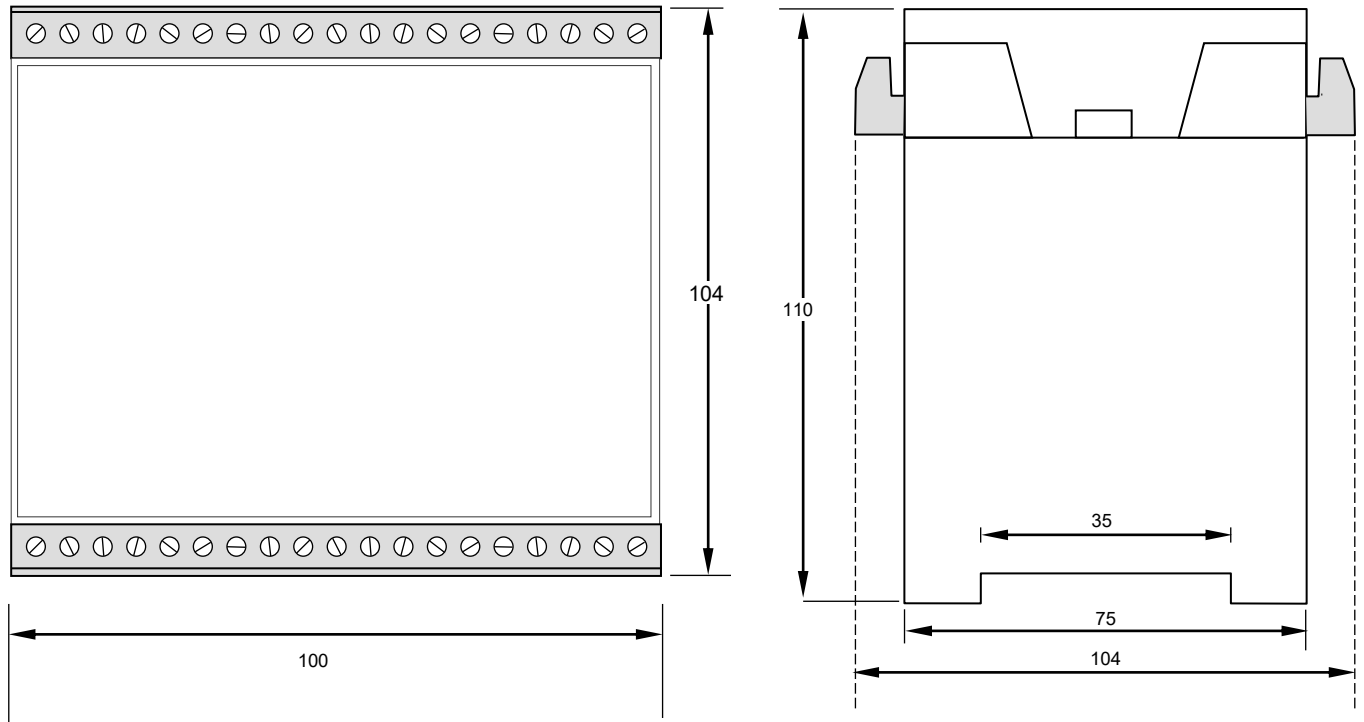

## Dimensions for optional field mounting enclosure IP65

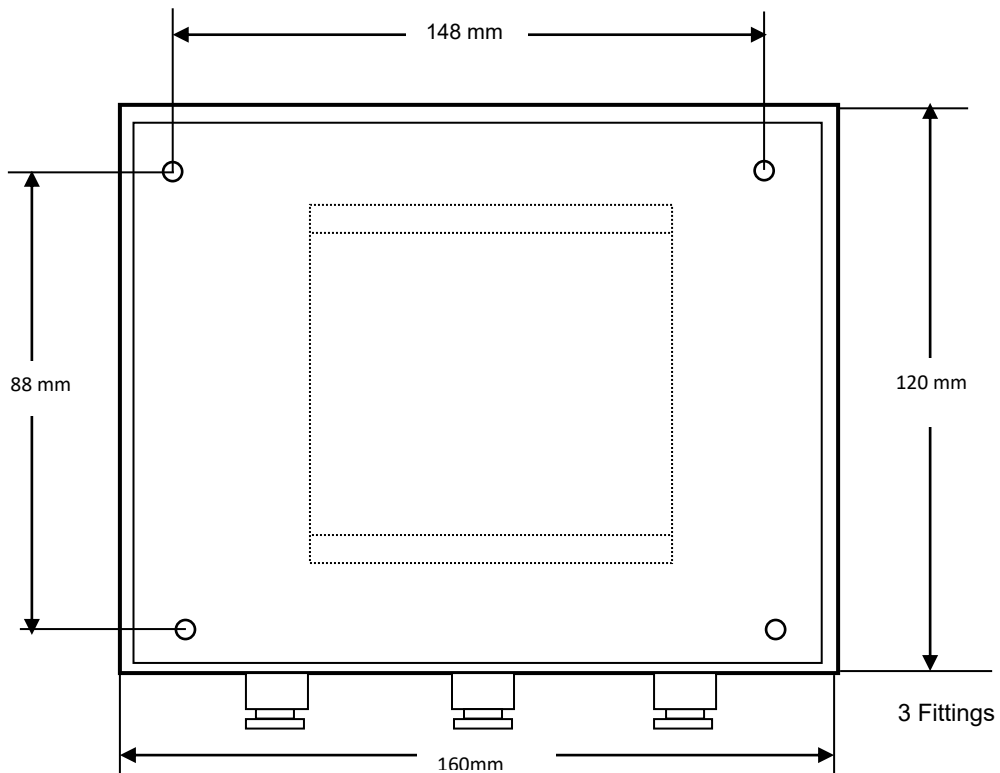

## Programming

### Summary of programming steps and their initial parameters as set on delivery

program- Step No.	parameter function	data set on delivery *) (initial data)
P00.00	access code request	0000
.01	new code figure	0000
.02	lock status (1=unlocked, 0=locked)	1 = unlocked
.03	minimum measuring time (0005 to 9999 msec)	0005
.04	time elapse of starter phase (XXX sec)	000
P01.00	scaling input	decimals of input signal frequency
.01		value of nominal input frequency
.02		decimals of corresponding speed
.03		corresponding speed (unit as desired)
.04		low end of speed range
.05		reserved for future application
.06		reserved for future application
.07		reserved for future application
.08		sensor monitoring: 0 = off / 1 = on / 2 = on and latched
.09		mode of monitoring: 0 = none / 1 = current / 2 = level / 3 = both
.10		fix value
P02.00	Display	LSDs on zero
.01		display updating sequence
P03.00	Analog output	reserved for future application
.01		high end value
.02		low end value
.03		zero level: 0=dead zero, 1=live zero
.04		fix value
.05		output level at sensor failure: 0=no change, 1=min, 2=max
.06		output characteristics: 0=linear increase, 1=linear decrease
P04.00	SP1	type of speed sensor: 0=F/R / 1=F/F
.01		time period for reset of reverse pulse counter (xxx seconds)
.02		minimum no of reverse pulses to release reverse alarm
.03		max deviation between speed inputs as percentage of P01.01
.04		relay state assigned to reverse: 0=energized, 1=de-energized
.05		forced direction at zero speed: 0=no, 1=forward, 2=reverse)
.06		reverse alarm latched until reset: 0=no, 1=yes
.07		relay state at sensor failure: 0=no change, 1=forward, 2=reverse

summary is continued on next side

P05.00	SP2	assigned to: 0=speed, 1=identical as SP1	0 = speed
.01		setpoint value in unit as programmed for display	01100
.02		hysteresis bandwidth (XX.X % of SP2)	05.0 (%)
.03		hysteresis location: 0=above, 1=below	0=above SP2
.04		relay state at n>SP2: 0=energized, 1=de-energized	1 = de-energized
.05		starter function effective for SP2: 0=not, 1=yes	1=yes
.06		alarm output assigned to starter phase	1 = n>SP2
.07		alarm state at sensor failure: 0=no change, 1=n>SP2, 2=n<SP2	0 = no change
P06.00	SP3	assigned to: 0=speed, 1=identical as SP1	0 = speed
.01		setpoint value in unit as programmed for display	01200
.02		hysteresis bandwidth (XX.X % of SP3)	05.0 (%)
.03		hysteresis location: 0=above, 1=below	0=above SP3
.04		relay state at n>SP3: 0=energized, 1=de-energized	1 = de-energized
.05		starter function effective for SP3: 0=not, 1=yes	1=yes
.06		alarm output assigned to starter phase	1 = n>SP3
.07		alarm state at sensor failure: 0=no change, 1=n>SP3, 2=n<SP3	0 = no change
P07.00	SP4	assigned to: 0=speed, 1=identical as SP1	0 = speed
.01		setpoint value in unit as programmed for display	01300
.02		hysteresis bandwidth (XX.X % of SP4)	05.0 (%)
.03		hysteresis location: 0=above, 1=below	0=above SP4
.04		relay state at n>SP4: 0=energized, 1=de-energized	1 = de-energized
.05		starter function effective for SP4: 0=not, 1=yes	1=yes
.06		alarm output assigned to starter phase	1 = n>SP4
.07		alarm state at sensor failure: 0=no change, 1=n>SP4, 2=n<SP4	0 = no change
P08.00	Data Interface	(baud rate of RS232-interface)	3 = 19200
.01		"device no" in communication	008

\*) unless stated otherwise in extra sheet.

## Short form Parameter-programming instruction

Principle: Select a Parameter by its "Name" **Pgg.ss**,  
 where **gg** = Parameter- Group-No. and  
**ss** = Step-No. within Group,  
 then check its value and possibly change it.

### Programming:

To enter the programming phase, press both keys **P** and **E** simultaneously; instead of normal display, P00.00 will be shown.

Select group- or step-no. with keys **Δ**, **∇**.

Toggle between group- and step-range with key **◀**.

Show parameter's value with key **E**.

Select (move) active digit with key **◀**.

Adjust figure in active digit with keys **Δ**, **∇**.

Acknowledge with key **E**, Cancel (old value still valid) with key **P**.

Return to normal operation with key **P**

Example: change value of parameter P01.01 from 2386 to 2387 or 2385:

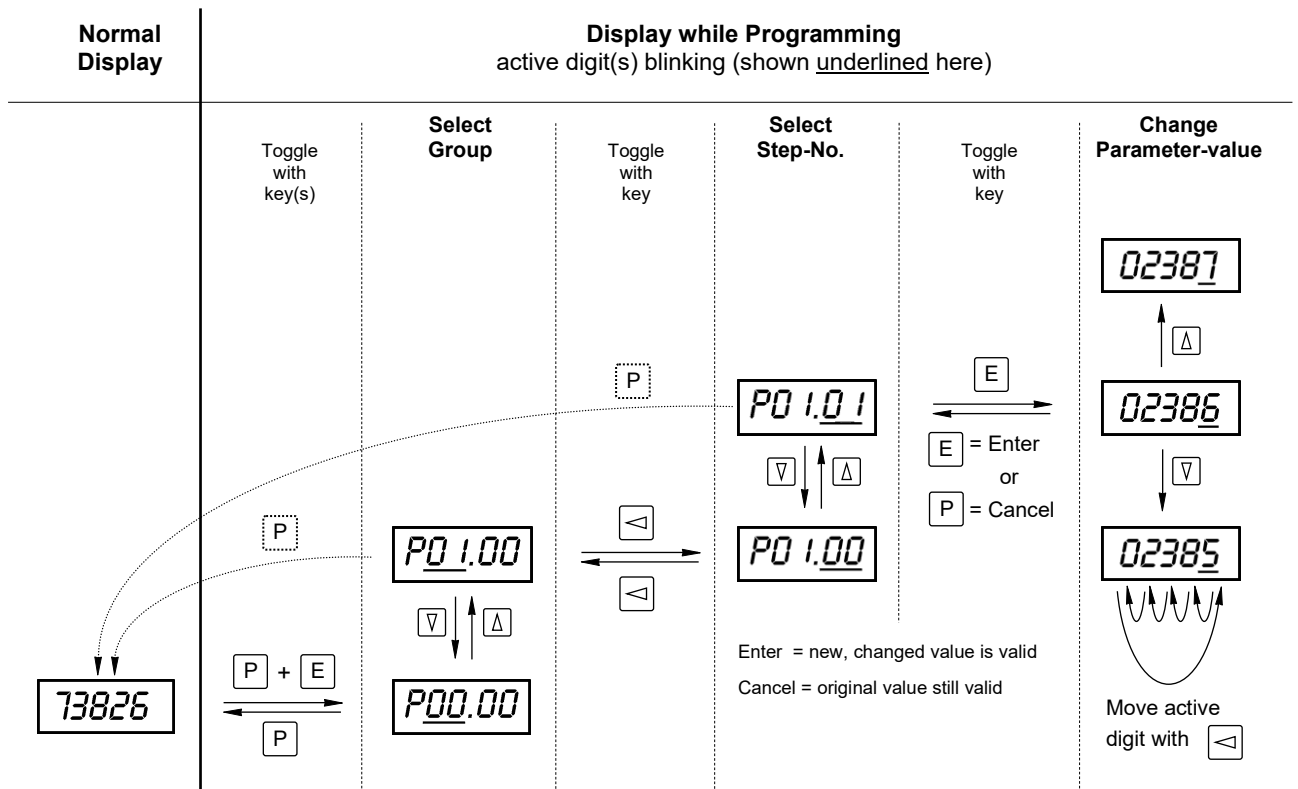

## Programmable Parameters

### Parameter Group P00.xx: Data Access, Minimum Measuring Period, Starter Time

#### Key figure to access

Programming access to all parameters can be locked by a password number. If not properly served, the parameters may be called to display but not varied. If not properly served, the display reads -E1-, and any programming in a later program step will be rejected.

Note: If the knowledge of the password number went lost it may be recalled to display by a procedure, as described in a separate sheet K0-095 (not included into these instructions). The code figure then appears by 4 digits, headed by a \_ sign.

In a subsequent program step, a new code may be established, substituting the one previously valid.

The key function may be disengaged by a next program step. With authorized access, set parameter to 1 in step No .02, to generally unlock the key. This may prove practical during the installation phase to facilitate the adjustments. Once installed, the key function should be reactivated, by programming parameter 0 in this step.

Note: The display-updating-sequence will be defined in a separate program step

#### Minimum Measuring Period

The measurement is based on a time interval measurement over a (variable) number of input signal pulses. A programmable minimum measuring period thus will be maintained, automatically including more input pulses into every measurement with increasing input frequency. This establishes an averaging over the programmed period of time, which helps to stabilize the measurements, specifically with fluctuating variables. As a standard, a minimum time of 300 millisecc is recommended. A shorter period should be selected to trace a fast variation (by the analog signal or alarm). A longer period however may be selected to stabilize the measurement against a fluctuating process variable.

The parameter of P01.05 defines the minimum measuring period of time, in terms of milliseconds, within a range of 0005....9999 millisecc. A setting less than 0005 will be ignored.

#### Starter phase time extension

The starter condition is true as long as the signal at terminal 26 (versus reference, terminal 20) is high (24 volts).

The starter condition can be extended by the starter time elapse.

This time starts as soon as the contact between terminals 4 and 5 is opened. The starter time extension is set in program step P00.04 within the range 000...999 (sec). The programmed time is valid for all setpoints.

Step **P00.00**:  
Code figure to access

Step **P00.01**:  
new code figure

Step **P00.02**:  
unlock access key

averaging  
over  
minimal period of time

Step **P00.03**:  
minimum measuring time  
0005msec to 9999 msec.

Step **P00.04**:  
Starter phase time extension

**Parameter Group P01.xx:  
Measurement Configuration**

Scaling defines the relation between the input signal frequency (in terms of Hz), and the corresponding display (in the unit term and decimal position required by the application). Both values are freely programmable by their decimals and numerical amount. Of course, they must refer to the same operation level. This reference point is recommended close to the high end of the intended operation range. In later operation however, it may be overrun without error.

**General Note to Resolution:**

Do not use too many decimals! If there are more decimals than justified by the operational fluctuation of the variable, and the transmitter resolution, the minor digits in display will fluctuate accordingly, and also the analog output will not be stable.

**Low end for shut-off**

If the variable falls lower than this level, the measurement will be cancelled to zero. With corresponding readings to difference and ratio. This also applies to the analog output and the alarms.

The low end is programmed by the same terms, as defined for the variable by steps P01.02 and P01.03.

Reserved for future application

Reserved for future application

Reserved for future application

**Sensor Monitoring Enable, only with sensor series A5S... possible**

If the sensor is monitored (if applicable to sensor), the failure alarm may be latched until it is reset.

**Setting**

- 0 : sensor monitoring disabled
- 1 : active, alarm not latched
- 2 : active, alarm latched

Note: If set to 0, the setting of P01.09 is obsolete.

**Sensor Monitoring Mode**

The sensor can be monitored for its current drain (alarm if current drops below 2 ma (interrupt) or exceeds 80 mamps (short circuit in sensor supply). The signal lead can be monitored (at zero speed) to detect an interrupt there or a wrong connection). This function presumes a strong push-pull sensor characteristics (as with BRAUN A5S.. series of sensors).

**Setting**

- 0 : no monitoring
- 1 : current monitoring
- 2 : signal level monitoring
- 3 : current and signal level

Note: If set to 0, the setting of P01.08 is obsolete.

signal frequency (Hz):

Step **P01.00** =  
number of decimals,

Step **P01.01**= value.

corresponding value of quantity  
(any term):

Step **P01.02** =  
number of decimals,

Step **P01.03** = value

Step **P01.04**  
low end of operating  
range

Step **P01.05**  
Reserved

Step **P01.06**  
Reserved

Step **P01.07**  
Reserved

Step **P01.08**:  
Sensor Monitoring Enable  
Range: 0 to 2

Step **P01.09**:  
Sensor Monitoring Mode  
Range: 0 to 3

Step **P01.10**  
fix value = 001

## Parameter Group P02.xx Display

### LSDs on zero

If the display of the variable uses 3 or more digits, for application reasons, the lesser significant digits (LSD) may appear fluctuating if the variable does not have adequate stability. To avoid irritations by not significant digits, a number of them may be permanently kept at zero.  
Set the parameter to the number of LSDs to be kept on zero.

Step **P02.00**:  
zeroing LSDs

### Display updating sequence

Independent from the response time used for other functions, the display may have its own up-dating sequence - again in the interest of stabilized and well legible readings. Set the parameter to the time in steps of 0.1 sec. up to 9.9 sec. A recommended value is 0.3 sec.

Step **P02.01**:  
display updating

## Parameter Group P03.xx Analog Output

### High end of the conversion span

The high end (corresponding to 20 ma/10 v) is programmed by the same terms (RPM) as used in step P01.03. Independent however, in its level.

### Low end of the conversion span

Also, the required low level (corresponding to 0/4ma).

#### Note:

This allows the low end to be set as high as 90 % of the high end, resulting in a 10 times spreading (enhancement) of the converted band. Further enhancement is not recommended.

### Analog output zero

The parameter of this step defines:

0 = without live zero (0..20 ma)

1 = with live zero (4..20 ma)

### Level of Analog Output at sensor failure condition

0 = no change of output

1 = output goes to < 0 ma

2 = output goes to > 20 ma

### Characteristics of Analog Output

0 = output is increasing with increasing speed

1 = output is decreasing with increasing speed

With both however, the relation between output signal and quantity measured is linear.

#### Step P03.00:

Reserved for future application

#### Step P03.01:

high end of analog output

#### Step P03.02:

low end of analog output

#### Step P03.03:

zero of analog output

#### Step P03.04

fix value=1

do not change

#### Step P03.05

Level of analog output at sensor failure condition

#### Step P03.06

Characteristics of analog output increasing/decreasing

**Program Range P04.xx:  
Defining Direction Alarm SP1**

Defining Alarm **SP1**

**Sensor connected to D225:**

0 = A5S30 to A5S33 resp. A5S14 to A5S17 resp. A5SxDS3 resp. A5SxDD3  
F/R-Sensors (1x Frequency / 1x Direction of Rotation)  
1 = A5S40 to A5S43 resp. A5SxDS4 resp. A5SxDD4  
F/F-Sensors (2x Frequency/Frequency)

Note:

x = 0 : non Ex Sensors

x = 1 : Ex Sensors (to be connected via D461)

Step **P04.00:**

Sensor connected

**Time period for reset of reverse pulse counter**

A slow reverse motion could trigger an inadvertent reverse alarm. To prevent this, the reverse pulse counter is periodically reset after an adjustable time period (001 to 999 seconds).

Step **P04.01:**

Time period to reset reverse pulse counter

**Minimum number of reverse pulses to release reverse alarm**

Reverse alarm is released, if during a given time period (refer to P04.01) a subsequent number of reverse pulses have been counted. The amount of pulses is adjustable from 01 to 99 pulses.

Step **P04.02:**

Minimum number of reverse pulses

**Maximum Deviation between speed signals of A5S.. sensors**

If the maximum allowable deviation between the two speed signals of an A5S.. sensor is exceeded, a sensor failure is detected and the alarm SE-40 displayed.

The maximum allowable deviation is introduced as percentage of nominal speed value (see P01.01).

Step **P04.03:**

Maximum allowable deviation between two speed signals of A5S.sensors.

**Relay state SP1 at Direction Reverse**

0 = energized at Direction Reverse

1 = deenergized at Direction Reverse

Step **P04.04:**

Relay state SP1 at Direction Reverse

**Direction signal at zero speed**

When the speed is below the threshold set by program step P01.04, the direction output can be set to a signal position determined by the parameter:

0 = no change

1 = forward

2 = reverse

Note: Settings 1 or 2 override the direction signal prevailing in the sensor output under this condition.

Step **P04.05:**

Direction signal at zero speed

**Reverse alarm latched/not latched**

A reverse alarm can be latched. It must be then reset by control input S2.

0 = alarm not latched

1 = alarm is latched.

Step **P04.06:**

Reverse alarm latched/not latched

**Response of Direction output of SP1 to state "sensor failure" (see P04.03)**

0 = no change

1 = set to forward

2 = set to reverse

Step **P04.07:**

Response to sensor failure

**Program Range P05.xx:  
Defining Alarm SP2**

Defining Alarm **SP2**

**Assignment of alarm to speed or identical to SP1**

0 = alarm is assigned as speed alarm  
1 = alarm is assigned to direction and has identical response as SP1 (all other steps of this group then are irrelevant)

Step **P05.00:**  
Assignment of alarm

**Setpoint**

Setpoint SP2 is programmed in the same terms (rpm) as selected for the display of the speed.

Step **P05.01:**  
Setpoint SP2

Each setpoint is freely adjustable over the entire range.

**Alarm Hysteresis**

The hysteresis is the margin between condition "excess" (>) and "no excess" (<), defined by its bandwidth. The hysteresis bandwidth is set as a percentage of the setpoint.

Step **P05.02:**  
band width of hysteresis of SP2 as XX.X %

**Hysteresis position**

The hysteresis band may be placed above setpoint, below setpoint, or symmetrically around the setpoint.

"Above" means, the alarm goes to excess state (>), when the speed exceeds "setpoint plus tolerance", and it cancels to no-excess (<), when the speed drops below setpoint.

Set parameter 0 for this performance.

"Below" means, the alarm goes to excess (>), when the speed exceeds the setpoint, and it cancels to no-excess (<), when the speed drops below "setpoint minus tolerance".

Set parameter to 1 for this performance.

Step **P05.03:**  
hysteresis position  
0 = above SP2  
1 = below SP2

Without power supply, the alarm outputs are non-conducting, and the relays are de-energized. To consider safety aspects of the application, this **No-Power condition** can be assigned to either alarm n>SP or n<SP condition by parameter selection.

Step **P05.04:**  
relay-state if n > SP1:

0 : energized  
1 : de-energized =  
No-Power condition

**Setpoint included/not included in starter function**

This step defines, individually for each alarm, whether or not it is included into the starter function. Thereby it is possible, for instance, to disable a low speed alarm during the starter phase, whereas a high-speed alarm remains active all the time.

In the corresponding program step, set  
0 = exclude the alarm from the starter function,  
1 = include the alarm into the starter function

Step **P05.05:**  
Setpoint included / not included in starter function  
0 = not included  
1 = included

**Relay state at starter condition (if included)**

0 = throw the alarm to < setpoint,  
1 = throw the alarm to > setpoint.

**Response of alarm output of SP1 to state "sensor failure"**

Selection of:

0 = ignore sensor failure, normal comparison with speed  
1 = set to condition  $n < SP2$   
2 = set to condition  $n > SP2$

**Step P05.06:**

Relay state at starter condition  
0 =  $n < SP2$   
1 =  $n > SP2$

**Step P05.07:**

Response to sensor failure  
setting:  
0 = no change  
1 =  $n < SP2$  alarm  
2 =  $n > SP2$  alarm

### Program Range P06.xx: Defining Alarm SP3

Alarm SP3 will be defined like SP2:

- Step **P06.00**: assign alarm to speed or to SP1
- Step **P06.01**: Setpoint
- Step **P06.02**: band width of hysteresis as XX.X %
- Step **P06.03**: hysteresis position
- Step **P06.04**: relay-state if  $n > SP$
- Step **P06.05**: Setpoint included / not included in starter function
- Step **P06.06**: Relay state at starter condition
- Step **P06.07**: Response to sensor failure

### Program Range P07.xx: Defining Alarm SP4

Alarm SP4 will be defined like SP2:

- Step **P07.00**: assign alarm to speed or to SP1
- Step **P07.01**: Setpoint
- Step **P07.02**: band width of hysteresis as XX.X %
- Step **P07.03**: hysteresis position
- Step **P07.04**: relay-state if  $n > SP$
- Step **P07.05**: Setpoint included / not included in starter function
- Step **P07.06**: Relay state at starter condition
- Step **P07.07**: Response to sensor failure

### Parameter Group P08.xx Defining Data Interface Parameters for RS232, resp. PROFIBUS

#### Baud rate

- 0 = 00300 Baud
- 1 = 01200
- 2 = 09600
- 3 = 19200
- 4 = 38400

#### Device No in communication

"my device" No (address),...001 - 127

Step **P08.00**:  
Baud Rate  
(not relevant for PROFIBUS)

Step **P08.01**:  
Device no in communication  
range 001 - 127

### **Programming of the D22511 or D224.11S2 via RS232-Interface**

Only possible with interface-software IS-RS232-S and cable L3D03.

### **Programming of the D225.12 or D224.12S2 via PROFIBUS-Interface**

See separate Manual „D224\_D225\_Profibus\_EN.pdf“