

Manual

Isolating Barrier D461R1

(Revision 06)

Product Manual

Original Instructions

valid for models

D461R1.11 with 1x signal input into 1x isolated signal output

D461R1.12 with 1x signal input into 2x isolated signal output parallel

D461R1.21 with 2x signal input into 2x isolated signal output



D461R1 Front view

Isolating Barrier with sensor supply and circuit monitoring

ATEX

 II (1) G [Ex ia Ga] IIC

CE 0123

CML 15ATEX2128X

Table of Contents

Content	Page
Table of Contents	2
1 General Information	4
1.1 List of Figures.....	4
1.2 Functions and Application.....	5
1.3 Installation.....	5
1.4 Sensor Monitoring and Sensor Calibration at zero speed condition.....	5
1.4.1 Sensor Monitoring.....	5
1.4.2 Sensor Calibration at zero speed condition.....	5
1.5 Circuit Isolation.....	6
1.6 Ordering key for isolating barriers series D461R1.....	6
1.7 General Certificates / Approvals.....	6
1.7.1 EU Declaration of Conformity.....	7
1.8 A5S1 Sensors operated with D461R1 Barriers.....	8
2 Hazardous Protection	9
2.1 Relevant technical Data for Hazardous Area.....	9
2.2 ATEX Certification for Intrinsic Safety of the Input Circuit.....	9
2.3 Explosive relevant Certificates / Approvals.....	9
2.3.1 ATEX.....	9
2.3.2 IECEx.....	9
2.3.3 USA (NEC) and Canada (CEC).....	9
2.3.4 Reserved.....	9
2.3.5 UKEX.....	10
2.3.6 KCs.....	10
2.3.7 ATEX EU Type Examination Certificate.....	11
2.3.8 IECEx Certificate of Conformity.....	15
2.3.9 NEC/CEC Certificate of Conformity.....	19
2.3.10 Reserved.....	21
2.3.11 UKEX UK Type Examination Certificate.....	22
2.3.12 KCs Certificate.....	26
2.3.13 Control Drawing D461R1.11.....	28
2.3.14 Control Drawing D461R1.12.....	29
2.3.15 Control Drawing D461R1.21.....	30
3 Function Diagram and Connections	31
3.1 Function Diagram and Connection D461R1.11.....	31
3.2 Function Diagram and Connection D461R1.12.....	32
3.3 Function Diagram and Connection D461R1.21.....	33
4 Technical Specifications	34
4.1 Technical Data of Inputs (intrinsic safe).....	34
4.2 Technical Data of Outputs.....	34
4.3 Technical Data of Power Supply.....	34
4.4 Environmental conditions.....	34
4.5 Protection Grade.....	34
4.6 Connectors.....	35
4.7 Conformity to Standards.....	35
4.8 Dimensions.....	36
4.9 Weight.....	36

5	Safety Notes for Installation and Operation.....	37
5.1	Safety Notes for Installation.....	37
5.1.1	General Instructions.....	37
5.1.2	EMI	37
5.2	Safety Notes for Operation.....	37
5.2.1	Safety Notes on Commissioning.....	37
6	Revision Notes	38

1 General Information

1.1 List of Figures

Figure 1:	EU Declaration of Conformity	7
Figure 2:	ATEX EU Type Examination Certificate part 1	11
Figure 3:	ATEX EU Type Examination Certificate part 2	12
Figure 4:	ATEX EU Type Examination Certificate part 3	13
Figure 5:	ATEX EU Type Examination Certificate part 4	14
Figure 6:	IECEX Certificate of Conformity part 1	15
Figure 7:	IECEX Certificate of Conformity part 2	16
Figure 8:	IECEX Certificate of Conformity part 3	17
Figure 9:	IECEX Certificate of Conformity part 4	18
Figure 10:	NEC/CEC Certificate of Conformity part 1	19
Figure 11:	NEC/CEC Certificate of Conformity part 2	20
Figure 12:	Reserved	21
Figure 13:	Reserved	21
Figure 14:	Reserved	21
Figure 15:	Reserved	21
Figure 16:	UKEX UK Type Examination Certificate part 1	22
Figure 17:	UKEX UK Type Examination Certificate part 2	23
Figure 18:	UKEX UK Type Examination Certificate part 3	24
Figure 19:	UKEX UK Type Examination Certificate part 4	25
Figure 20:	KCs Certificate part 1	26
Figure 21:	KCs Certificate part 2	27
Figure 22:	Control Drawing D461R1.11	28
Figure 23:	Control Drawing D461R1.12	29
Figure 24:	Control Drawing D461R1.21	30
Figure 25:	Function Diagram and Connection D461R1.11	31
Figure 26:	Function Diagram and Connection D461R1.12	32
Figure 27:	Function Diagram and Connection D461R1.21	33
Figure 28:	Dimensions of unit D461R1	36

1.2 Functions and Application

The isolating barrier establishes an intrinsic safety circuit (Ex ia) feeding the sensor, and receiving the sensor signal. The incorporated optocoupler separates this input from the subsequent circuit. The output of the unit repeats the input pulse signals, with inverted sequence but enforced level, to feed electronic measurements, alarms, totalizers, or controllers. Characteristics of the input circuit immediately match the specifications of the speed sensor series A5S1..., which are approved as intrinsic safety devices, to be installed in a hazardous area if properly supplied. The barrier unit D461R1... must be placed in a safe (non-hazardous) area, or within an explosion-proof enclosure.

A speed sensor series A5S1..., in combination with the barrier D461R1... thereby establishes an efficient speed sensing system, to supply high-level output signals to the periphery.

Version D461R1.11

The barrier D461R1.11 incorporates one signal input for single-channel sensors and one signal output.

Version D461R1.12

The barrier D461R1.12 incorporates one signal input for single-channel sensors and two signal outputs. Both signal outputs repeat the input pulse signal.

Version D461R1.21

The barrier D461R1.21 incorporates two signal inputs for dual-channel sensors and two signal outputs. The signal outputs repeat one input pulse signal each.

1.3 Installation

The barrier D461R1... is designed for indoor use (NEMA 1), e.g. within switchboards, racks or cabinets. Screw mounting or snap-on-track (DIN 50022 / 35 mm) can be used. Protection grade IP20.

As a special version, the barrier is available in enclosure grade IP65 (NEMA4), or in explosion-proof enclosure (Exd II C T5).

1.4 Sensor Monitoring and Sensor Calibration at zero speed condition

1.4.1 Sensor Monitoring

The sensor supply circuit is monitored against lead break and short circuit. Speed signal input on terminal 23 is monitored for open lead. In case of detected fault, the alarm relay (terminals 6 and 8) is disengaged and signal on terminal 11 gets high ohmic.

An additional transistor output is non-conductive in the case of a fault. The transistor output (terminal 13) can be connected to the sensor supply of a subsequent module, thus enabling its own sensor supply circuit monitor.

1.4.2 Sensor Calibration at zero speed condition

At zero speed condition respective signal frequencies $< 0,1$ Hz the sensor supply is shut down periodically for approx. 100 ms. Thereby the sensor is automatically re-calibrated.

Note:

With sensors with integrated direction detection the direction signal output F/R (terminal 12) may go low also for approx. 100 ms.

1.5 Circuit Isolation

Input, output and power supply are isolated from each other.
The output circuit must not be connected to other devices having an operational voltage exceeding 375 volts (peak).

1.6 Ordering key for isolating barriers series D461R1...

D461R1. a b

Channels incorporated

- a = 11 : 1x signal input into 1x isolated signal output
- a = 12 : 1x signal input into 2x isolated signal output parallel
- a = 21 : 2x signal input into 2x isolated signal output

Supply voltage

- b = U1 : 18...40 Vac/Vdc
- b = U2 : 85...250 Vac

Examples:

D461R1.11U2 = with 1x signal input into 1x isolated signal output for 85...250 Vac

D461R1.11U1 = with 1x signal input into 1x isolated signal output for 18...40 Vac/Vdc

D461R1.12U1 = with 1x signal input into 2x parallel isolated signal output for 18...40 V Vac/Vdc

D461R1.21U2 = with 2x signal input into 2x isolated signal output for 85...250 Vac

1.7 General Certificates / Approvals



BRAUN GmbH Industrie-Elektronik, Esslinger Str. 26, 71334 Waiblingen, Germany
 erklärt in alleiniger Verantwortung, declares in its sole responsibility,

dass das Produkt:
 that the product:

Trennstufe
Isolating Barrier

Typ(en), types:

D461R1...

den genannten Europäischen Richtlinien und harmonisierten Normen entspricht, is in conformity with the listed European Directives and harmonized standards.

EU-Richtlinie(n) / EU-Directive(s)	Norm(en), Standard(s)
2014/30/EU 2014/30/EU EMV-Richtlinie EMC Directive	EN 61326-1:2013 EN IEC 61326-3-2:2018
2014/35/EU 2014/35/EU Niederspannungsrichtlinie Low Voltage Directive (LVD)	EN 61010-1:2010+A1:2019
2011/65/EU 2011/65/EU RoHS-Richtlinie RoHS Directive	EN IEC 63000:2018
2014/34/EU 2014/34/EU ATEX-Produktrichtlinie ATEX Product Directive	EN IEC 60079-0:2018 EN 60079-11:2012

Kennzeichnung, marking:

II (1) G [Ex ia Ga] IIC

0123

EU-Baumusterprüfbescheinigung Nr.:
 EU Type Examination Certificate No:
Aussteller, notified Body:

CML 15ATEX2128X

Certification Management Limited B.V. (CML)
 Hoogoorddreef 15
 Amsterdam, 1101 BA
 The Netherlands

Benannte Stelle Nr., notified Body No:

2776

BRAUN erklärt hiermit, dass das Produkt nur von kleineren oder formalen Änderungen in Bezug auf die neue Ausgabe der Normen betroffen ist. Diese Änderungen sind nicht relevant für die Konformität mit den wesentlichen Gesundheits- und Sicherheitsanforderungen. Das Produkt erfüllt nach wie vor die ATEX-Richtlinie. Diese Erklärung gilt auch, wenn die Kennzeichnung und die Zertifikate des aufgeführten Geräts vorangegangenen Normenständen entsprechen.

BRAUN declares that the product is only affected by minor or formal changes with respect to the new edition of the standards. These changes are not relevant for compliance with the essential health and safety requirements. The product still complies with the ATEX Directive. This declaration is also valid if the marking and the certificates of the listed device corresponds to previous editions of standards.

Diese Erklärung gilt für alle Produkte, die mit Typenschildern der oben genannten Typen versehen sind.

Zusatzbezeichnungen an Stelle von ... stehen für die spezifische Ausführung.

This declaration is valid for all products, which are provided with type labels of the types mentioned above.

Suffixes instead of ... are dummy variables for the specific model.

Unbedingte Beachtung aller Punkte der mitgelieferten Betriebsanleitung ist hierbei Voraussetzung.

Strict observance of the operation manual is an indispensable precondition, hereto.

Unterzeichnet für und im Namen der BRAUN GmbH / Signed for and on behalf of BRAUN GmbH

Waiblingen, 09-JAN-2024

Ort und Datum
 Place and date

Albrecht Braun
Geschäftsführer
 Managing Director



Figure 1: EU Declaration of Conformity

1.8 A5S1 Sensors operated with D461R1 Barriers

Valid for applications in hazardous areas only:

A5S1 sensors with EU Type Examination Certificate
CML 14ATEX2075X are allowed to be operated in conjunction with D461R1... barriers.

A5S1 sensors with expired EU Type Examination Certificate
TPS 03ATEX1005X are not allowed to be operated in conjunction with D461R1... barriers.

2 Hazardous Protection

The safety requirements as determined by EN 1127-1, as well as the corresponding national regulations, are to be complied with regarding primary explosion protection, i.e. measures which prevent or restrict the formation of a hazardous explosive atmosphere.

In the case of secondary hazardous protection, i.e. measures that prevent the ignition of an explosive atmosphere surrounding electrical equipment, the series of standards applicable to EN 60079 and the relevant national regulations must be observed.

2.1 Relevant technical Data for Hazardous Area

Approved maximum values:

U_o = 8.7 V

I_o = 64 mA

P_o = 384 mW

L_o = 7.9 mH (IIC)

= 38 mH (IIB)

C_o = 5.9 μF (IIC)

= 50 μF (IIB)

2.2 ATEX Certification for Intrinsic Safety of the Input Circuit

 II (1) G [Ex ia Ga] IIC

Marking of notified Body: CE0123

EU Type Examination Certificate: CML 15ATEX2128X

2.3 Explosive relevant Certificates / Approvals

2.3.1 ATEX

The isolating barrier series D461R1... is certified according to ATEX EU Type Examination Certificate No. CML 15ATEX2128X and is compliant according to ATEX Product Directive 2014/34/EU. Marking see ATEX EU Type Examination Certificate chapter 2.3.7.

2.3.2 IECEX

The isolating barrier series D461R1... is certified according to IECEX Certificate of Conformity No. CML 15.0063X. Marking see IECEX Certificate of Conformity chapter 2.3.8.

2.3.3 USA (NEC) and Canada (CEC)

The isolating barrier series D461R1... is certified for the USA and Canada according to QPS Certificate of Conformity No. LR 1323-2. Marking see NEC/CEC Certificate of Conformity chapter 2.3.9.

2.3.4 Reserved

2.3.5 UKEX

The isolating barrier series D461R1... is certified for UKEX according to UKEX UK Type Examination Certificate No. CML 21UKEX2052X and are compliant according to UK statutory requirements SI 2016 No. 1107. Marking see UKEX UK Type Examination Certificate chapter 2.3.11.

2.3.6 KCs

The isolating barrier series D461R1... is certified for South Korea according to KCs certificate No. 21-AV4BO-0260X by KOSHA. Marking see KCs certificate chapter 2.3.12.



EU Type Examination Certificate CML 15ATEX2128X Issue 3

- 1 Equipment intended for use in Potentially Explosive Atmospheres Directive 2014/34/EU
- 2 Equipment **Isolating Amplifier D461**
- 3 Manufacturer **Braun GmbH Industrie-Elektronik**
- 4 Address **Esslinger Straße 26,
DE 71334, Waiblingen, Germany**
- 5 The equipment is specified in the description of this certificate and the documents to which it refers.
- 6 CML B.V., Chamber of Commerce No 67386717, Koopvaardijweg 32, 4906CV Oosterhout, The Netherlands, Notified Body Number 2776, in accordance with Article 17 of Directive 2014/34/EU of the European Parliament and of the Council, dated 26 February 2014, certifies that this equipment has been found to comply with the Essential Health and Safety Requirements relating to the design and construction of equipment intended for use in potentially explosive atmospheres given in Annex II to the Directive.
The examination and test results are recorded in the confidential reports listed in Section 12.
- 7 If an 'X' suffix appears after the certificate number, it indicates that the equipment is subject to conditions of safe use (affecting correct installation or safe use). These are specified in Section 14.
- 8 This EU Type Examination certificate relates only to the design and construction of the specified equipment or component. Further requirements of Directive 2014/34/EU Article 13 apply to the manufacture of the equipment or component and are separately certified.
- 9 Compliance with the Essential Health and Safety Requirements, with the exception of those listed in the confidential report, has been demonstrated through compliance with the following documents:
EN IEC 60079-0:2018 EN 60079-11:2012
- 10 The equipment shall be marked with the following:
 II (1) G
 [Ex ia Ga] IIC
 Ta= -20°C to +60°C



This certificate shall only be copied
in its entirety and without change
www.CMLEx.com

1 of 4

L. A. Brisk

L A Brisk
Assistant Certification Manager

Figure 2: ATEX EU Type Examination Certificate part 1



CML 15ATEX2128X
Issue 3

11 Description

The Isolating Amplifier D461 is an intrinsic safety associated apparatus for use in a safe area. It provides power to external speed sensors from an isolating switching transformer and conditions the associated speed signals for electronic measurements, alarms, totalizers, or controllers using an opto-coupler circuit.

The non-intrinsically safe circuitry is powered by an isolating switching transformer and monitors the speed sensor supply circuit for lead faults and annunciated by an alarm relay. The enclosure of the Isolating Amplifier D461 is designed to be installed on a DIN rail and meets the requirements of environmental protection IP 20.

Nomenclature:

D461 **R1** . **** U ***
A **B** **C** **D**

Where

A = D461 Type of Device
B = R1 Release 1
C = 11 Device one signal channel input, one signal channel output.
 12 Device one signal channel input, two signal channel output parallel.
 21 Device two signal channel input, two signal channel output
D = 1 Supply Voltage 18 to 40 Vac/Vdc
 2 Supply Voltage 85 to 250 Vac

Ratings

IS Sensor Outputs:

Terminals:	S1/4	22	Signal 2
	S1/3	23	Signal 1
	S1/2	24	+Sensor Feed
	S1/1	25	GND/Sensor Feed
Uo:	8.7 V		
Io:	64 mA		
Po:	384 mW		
Lo:	IIC	7.9 mH	
	IIB	38 mH	
Co:	IIC	5.9 μF	
	IIB	50 μF	
Note: Combined Lo and Co for Signal 1 and Signal 2			

This certificate shall only be copied
in its entirety and without change
www.CMLEx.com

2 of 4

Version: 7.0 Approval: Approved

Figure 3: ATEX EU Type Examination Certificate part 2



CML 15ATEX2128X
Issue 3

Power Supply:

Terminals	S3/1	1	L
	S3/2	2	N
Um (U1):	60 V		
Um (U2):	250 V		

Signal Outputs

Terminals:	S2/1	10	Output reference
	S2/2	11	Signal Output 1
	S2/3	12	Signal Output 2
	S2/4	13	Logic Alarm Output
Um:	60 V		

Signal Outputs

Terminals:	S3/3	6	Relay Alarm Output
	S3/4	8	Relay Alarm Output
Um:	60 V		
Relay Contacts:	30 Vdc, 2 A		

Variation 1

This variation introduces the following modifications:

- i. Repositioning of fuses F1 and F2 in the circuit
- ii. Removal of fuse F4
- iii. Change of thyristor package
- iv. Change of capacitor values
- v. Addition of a capacitor
- vi. Addition of 2 ferrite inductors
- vii. Addition of conformal coating to 230V version
- viii. Modification to PCB tracking

Variation 2

This variation introduces the following modifications:

- i. Increase the upper temperature range from +50°C to +60°C
- ii. Update applied standard- EN 60079-0:2012: A11:2013 Corr3 to EN IEC 60079-0:2018

12 Certificate history and evaluation reports

Issue	Date	Associated report	Notes
0	18 Jan 2017	R606A/00	Issue of prime certificate
1	13 Oct 2017	R11323A/00	Introduction of Variation 1
2	21 Jan 2019	R12231A/00	To transfer certificate to CML B.V
3	03 Apr 2024	R17191A/00	Introduction of Variation 2

Note: Drawings that describe the equipment or component are listed in the Annex.

This certificate shall only be copied
in its entirety and without change
www.CMLEx.com

3 of 4

Version: 7.0 Approval: Approved

Figure 4: ATEX EU Type Examination Certificate part 3



13 Conditions of Manufacture

The following conditions are required of the manufacturing process for compliance with the certification.

- i. Where the product incorporates certified parts or safety critical components, the manufacturer of the product defined on this certificate shall continually monitor these parts/components for any modifications introduced by the manufacturer(s) of these constituent parts. If the manufacturer of any constituent part introduces any changes which affect the compliance of the certified product that is the subject of this certificate, the manufacturer is required to have this certificate updated.
- ii. IEC 60079-11:2011 CL 11.2 Routine Tests for Infallible Transformers All transformers are shall subjected to following routine verification and test voltages:
 - 2,500 V, between input and output windings;
 - 1,000 V between all the windings and the core;
 - 1,500 V between each winding which supplies an intrinsically safe circuit and any other output winding;

The test voltage shall be applied for a period of at least 60 s.

Alternatively, the test may be carried out at 1,2 times the test voltage, but with reduced duration of at least 1 s.

The applied voltage shall remain constant during the test. The current flowing during the test shall not increase above that which is expected from the design of the circuit and shall not exceed 5 mA r.m.s. at any time. During these tests, there shall be no breakdown of the insulation between windings or between any winding and the core or the screen.

14 Specific Conditions of Use (Special Conditions)

The following conditions relate to safe installation and/or use of the equipment.

- i. The values of C_o and L_o apply when one of the two conditions below is given:
 - The total L_i of the external circuit (excluding the cable) is $< 1\%$ of the L_o value, or
 - The total C_i of the external circuit (excluding the cable) is $< 1\%$ of the C_o value.

The above parameters are reduced to 50% when both of the two conditions below are given:

- The total L_i of the external circuit (excluding the cable) $> 1\%$ of the L_o , and
- The total C_i of the external circuit (excluding the cable) $> 1\%$ of the C_o .

Note: the reduced capacitance of the external circuit (including cable) shall not be greater than 1 μ F for IIB and 600 nF for IIC.

Figure 5: ATEX EU Type Examination Certificate part 4

		<h1>IECEX Certificate of Conformity</h1>	
INTERNATIONAL ELECTROTECHNICAL COMMISSION IEC Certification System for Explosive Atmospheres <small>for rules and details of the IECEX Scheme visit www.iecex.com</small>			
Certificate No.:	IECEX CML 15.0063X	Page 1 of 4	Certificate history:
Status:	Current	Issue No: 2	Issue 1 (2017-10-13) Issue 0 (2017-01-30)
Date of Issue:	2024-04-03		
Applicant:	Braun GmbH Industrie Elektronik Esslingerstrasse 26 71334 Waiblingen Germany		
Equipment:	Isolating Amplifier D461		
Optional accessory:			
Type of Protection:	Intrinsic safety Ex "ia"		
Marking:	[Ex ia Ga] IIC Tamb: -20 °C to +60°C		
Approved for issue on behalf of the IECEX Certification Body:		L A Brisk	
Position:		Assistant Certification Manager	
Signature: (for printed version)			
Date: (for printed version)		03 Apr 2024	
1. This certificate and schedule may only be reproduced in full. 2. This certificate is not transferable and remains the property of the issuing body. 3. The Status and authenticity of this certificate may be verified by visiting www.iecex.com or use of this QR Code.			
Certificate issued by:			
Eurofins E&E CML Limited Unit 1, Newport Business Park New Port Road Ellesmere Port, CH65 4LZ United Kingdom		 	

Figure 6: IECEX Certificate of Conformity part 1



IECEX Certificate of Conformity

Certificate No.: **IECEX CML 15.0063X** Page 2 of 4
Date of issue: 2024-04-03 Issue No: 2

Manufacturer: **Braun GmbH Industrie Elektronik**
Esslingerstrasse 26
71334 Waiblingen
Germany

Manufacturing locations: **Braun GmbH Industrie Elektronik**
Esslingerstrasse 26
71334 Waiblingen
Germany

This certificate is issued as verification that a sample(s), representative of production, was assessed and tested and found to comply with the IEC Standard list below and that the manufacturer's quality system, relating to the Ex products covered by this certificate, was assessed and found to comply with the IECEx Quality system requirements. This certificate is granted subject to the conditions as set out in IECEx Scheme Rules, IECEx 02 and Operational Documents as amended

STANDARDS :

The equipment and any acceptable variations to it specified in the schedule of this certificate and the identified documents, was found to comply with the following standards

[IEC 60079-0:2017](#) Explosive atmospheres - Part 0: Equipment - General requirements
Edition:7.0

[IEC 60079-11:2011](#) Explosive atmospheres - Part 11: Equipment protection by intrinsic safety "i"
Edition:6.0

This Certificate **does not** indicate compliance with safety and performance requirements other than those expressly included in the Standards listed above.

TEST & ASSESSMENT REPORTS:

A sample(s) of the equipment listed has successfully met the examination and test requirements as recorded in:

Test Reports:

[GB/CML/ExTR15.0067/00](#)

[GB/CML/ExTR17.0173/00](#)

[GB/CML/ExTR23.0320/00](#)

Quality Assessment Report:

[DE/TPS/QAR12.0006/11](#)

Figure 7: IECEx Certificate of Conformity part 2



IECEX Certificate of Conformity

Certificate No.: **IECEX CML 15.0063X**

Page 3 of 4

Date of issue: 2024-04-03

Issue No: 2

EQUIPMENT:

Equipment and systems covered by this Certificate are as follows:

The Isolating Amplifier D461 is an intrinsic safety associated apparatus for use in a safe area that provide power to external speed sensors from an isolating switching transformer and conditions the associated speed signals for electronic measurements, alarms, totalizers, or controllers using an opto-coupler circuit.

See Annex for full description and Conditions of Manufacture

SPECIFIC CONDITIONS OF USE: YES as shown below:

See Annex for Specific Conditions of Use

Figure 8: IECEX Certificate of Conformity part 3



IECEX Certificate of Conformity

Certificate No.: **IECEX CML 15.0063X**

Page 4 of 4

Date of issue: 2024-04-03

Issue No: 2

DETAILS OF CERTIFICATE CHANGES (for issues 1 and above)

Issue 1

This issue introduces the following changes:

1. Repositioning of fuses F1 and F2 in the circuit
2. Removal of fuse F4
3. Change of thyristor package
4. Change of capacitor values
5. Addition of a capacitor
6. Addition of 2 ferrite inductors
7. Addition of coating to 230V version
8. Modification to the PCB tracking

Issue 2

This issue introduces the following changes:

1. Increase the upper temperature range from +50°C to +60°C.
2. Update the applied standard: IEC 60079-0:2011 Ed. 6 to IEC 60079-0:2017 Ed. 7

Annex:

[Certificate Annex IECEX 15.0063X Iss 2_1.pdf](#)

Figure 9: IECEX Certificate of Conformity part 4



QPS Evaluation Services Inc
 Testing, Certification and Field Evaluation Body
 Accredited in Canada, the USA, and Internationally

File
LR 1323

CERTIFICATE OF COMPLIANCE (ISO TYPE 3 CERTIFICATION SYSTEM)																																													
Issued to	Braun GmbH Industrie-Elektronik																																												
Address	Esslinger Straße 26, DE 71334 Waiblingen Germany																																												
Project Number	LR 1323-2R1																																												
Product	Isolating Amplifier D461R1**U*																																												
Model Number	<p>Nomenclature:</p> <p>D461 R1 . ** U * A B C D</p> <p>Where A = D461 Type of Device B = R1 Release 1 C = 11 Device one signal channel input, one signal channel output. 12 Device one signal channel input, two signal channel output parallel. 21 Device two signal channel input, two signal channel output D = 1 Supply Voltage 18 to 40 Vac/Vdc</p>																																												
Electrical Ratings	<p>Ratings U1: Supply Voltage: 18 to 40 Vac, 48 to 62 Hz or 18 to 40 Vdc; 3 VA Over-Voltage Category: II</p> <p>Hazardous (Classified Location) Ratings: Power Supply:</p> <table border="1"> <tr> <td>Terminals</td> <td>S3/1</td> <td>1</td> <td>L</td> </tr> <tr> <td></td> <td>S3/2</td> <td>2</td> <td>N</td> </tr> <tr> <td>Um (U1):</td> <td colspan="3">60 V</td> </tr> </table> <p>Signal Outputs:</p> <table border="1"> <tr> <td rowspan="4">Terminals:</td> <td>S2/1</td> <td>10</td> <td>Output reference</td> </tr> <tr> <td>S2/2</td> <td>11</td> <td>Signal Output 1</td> </tr> <tr> <td>S2/3</td> <td>12</td> <td>Signal Output 2</td> </tr> <tr> <td>S2/4</td> <td>13</td> <td>Logic Alarm Output</td> </tr> <tr> <td>Um:</td> <td colspan="3">60 V</td> </tr> </table> <p>Signal Outputs:</p> <table border="1"> <tr> <td rowspan="2">Terminals:</td> <td>S3/3</td> <td>6</td> <td>Relay Alarm Output</td> </tr> <tr> <td>S3/4</td> <td>8</td> <td>Relay Alarm Output</td> </tr> <tr> <td>Um:</td> <td colspan="3">60 V</td> </tr> <tr> <td>Relay Contacts:</td> <td colspan="3">30 Vdc, 2 A</td> </tr> </table>	Terminals	S3/1	1	L		S3/2	2	N	Um (U1):	60 V			Terminals:	S2/1	10	Output reference	S2/2	11	Signal Output 1	S2/3	12	Signal Output 2	S2/4	13	Logic Alarm Output	Um:	60 V			Terminals:	S3/3	6	Relay Alarm Output	S3/4	8	Relay Alarm Output	Um:	60 V			Relay Contacts:	30 Vdc, 2 A		
Terminals	S3/1	1	L																																										
	S3/2	2	N																																										
Um (U1):	60 V																																												
Terminals:	S2/1	10	Output reference																																										
	S2/2	11	Signal Output 1																																										
	S2/3	12	Signal Output 2																																										
	S2/4	13	Logic Alarm Output																																										
Um:	60 V																																												
Terminals:	S3/3	6	Relay Alarm Output																																										
	S3/4	8	Relay Alarm Output																																										
Um:	60 V																																												
Relay Contacts:	30 Vdc, 2 A																																												



The SCC and IAS Accreditation Symbols are official symbols of the respective accreditation bodies, used under license.
 81 Kelfield St., Unit 8, Toronto, ON M9W 5A3 Tel: 416-241-8857; Fax: 416-241-0682
 www.qps.ca



QSD 34HL

Rev 01

Figure 10: NEC/CEC Certificate of Conformity part 1



QPS Evaluation Services Inc
Testing, Certification and Field Evaluation Body
Accredited in Canada, the USA, and Internationally

File
LR 1323

IS sensor outputs:

Terminals:	S1/4	22	Signal 2
	S1/3	23	Signal 1
	S1/2	24	+Sensor Feed
	S1/1	25	GND/Sensor Feed
Uo:	8.7 V		
Io:	64 mA		
Po:	384 mW		
Lo:	IIC	7.9 mH	
	IIB	38 mH	
Co:	IIC	5.9 µF	
	IIB	50 µF	
Note: Combined Lo and Co for Signal 1 and Signal 2			

Markings

	Canada	US
Standards coding:	[Ex ia Ga] IIC	[AEx ia Ga] IIC
	Intrinsically Safe Associated Apparatus suitable for installation in non-hazardous locations with connections for Class I, Groups A, B, C and D, when installed in accordance with Control Drawing Ex-20112-CD-D461R1.**. (or equivalent wording)	
Ambient:	Ta: -20 °C to +60 °C	Ta: -20 °C to +60 °C

Applicable Standards

Canadian standards	US standards
CAN/CSA C22.2 No. 60079-0:19	ANSI/UL 60079-0:19
CAN/CSA C22.2 No. 60079-11:14	ANSI/UL 60079-11:2013
CSA C22.2 No. 61010-1-12	UL 61010:2015, Ed 3

Factory/Manufacturing Location

Same as above

Statement of Compliance: The product(s)/equipment identified in this Certificate and described in the Certification Report covered under the above referenced project number have been investigated and found to be in compliance with the relevant requirements of the above referenced standard(s). As such, they are eligible to bear the QPS Certification Mark shown below, in accordance with the provisions of QPS's Service Agreement.



Issued By: Dave Adams

Manager, Hazardous Locations Dept. [Ex Equipment]

Signature:

Date: July 9, 2024



The SCC and IAS Accreditation Symbols are official symbols of the respective accreditation bodies, used under license.
 81 Kelfield St., Unit 8, Toronto, ON M9W 5A3 Tel: 416-241-8857; Fax: 416-241-0682
 www.qps.ca



QSD 34HL

Rev 01

Figure 11: NEC/CEC Certificate of Conformity part 2

2.3.10 Reserved

Figure 12: Reserved
Figure 13: Reserved
Figure 14: Reserved
Figure 15: Reserved



UK Type Examination Certificate CML 21UKEX2052X Issue 1

United Kingdom Conformity Assessment

- 1 Product or Protective System Intended for use in Potentially Explosive Atmospheres UKSI 2016:1107 (as amended) – Schedule 3A, Part 1
- 2 Equipment **Isolating Amplifier D461**
- 3 Manufacturer **Braun GmbH Industrie Elektronik**
- 4 Address Esslinger Straße 26,
DE 71334, Waiblingen, Germany
- 5 The equipment is specified in the description of this certificate and the documents to which it refers.
- 6 Eurofins E&E CML Limited, Newport Business Park, New Port Road, Ellesmere Port, CH65 4LZ, United Kingdom, Approved Body Number 2503, in accordance with Regulation 42 of the Equipment and Protective Systems Intended for Use in Potentially Explosive Atmospheres Regulations 2016, UKSI 2016:1107 (as amended), certifies that this equipment has been found to comply with the Essential Health and Safety Requirements relating to the design and construction of equipment intended for use in potentially explosive atmospheres given in Schedule 1 of the Regulations.

The examination and test results are recorded in the confidential reports listed in Section 12.
- 7 If an 'X' suffix appears after the certificate number, it indicates that the equipment is subject to specific conditions of use (affecting correct installation or safe use). These are specified in Section 14.
- 8 This UK Type Examination certificate relates only to the design and construction of the specified equipment. Further requirements of the Regulations apply to the manufacturing process and supply of the product. These are not covered by this certificate.
- 9 Compliance with the Essential Health and Safety Requirements, with the exception of those listed in the confidential report, has been demonstrated through compliance with the following documents:

EN IEC 60079-0:2018 EN 60079-11:2012

- 10 The equipment shall be marked with the following:

 II (1) G
 [Ex ia Ga] IIC
 Ta= -20°C to +60°C



This certificate shall only be copied
in its entirety and without change
www.CMLEx.com

1 of 4

L Brisk

L A Brisk
Assistant Certification Manager

Figure 16: UKEX UK Type Examination Certificate part 1



CML 21UKEX2052X
Issue 1

11 Description

The Isolating Amplifier D461 is an intrinsic safety associated apparatus for use in a safe area. It provides power to external speed sensors from an isolating switching transformer and conditions the associated speed signals for electronic measurements, alarms, totalizers, or controllers using an opto-coupler circuit.

The non-intrinsically safe circuitry is powered by an isolating switching transformer and monitors the speed sensor supply circuit for lead faults and annunciated by an alarm relay. The enclosure of the Isolating Amplifier D461 is designed to be installed on a DIN rail and meets the requirements of environmental protection IP 20.

Nomenclature:

D461 **R1** . **** U ***
A **B** **C** **D**

Where

A = D461 Type of Device
B = R1 Release 1
C = 11 Device one signal channel input, one signal channel output.
 12 Device one signal channel input, two signal channel output parallel.
 21 Device two signal channel input, two signal channel output
D = 1 Supply Voltage 18 to 40 Vac/Vdc
 2 Supply Voltage 85 to 250 Vac

Ratings

IS Sensor Outputs:

Terminals:	S1/4	22	Signal 2
	S1/3	23	Signal 1
	S1/2	24	+Sensor Feed
	S1/1	25	GND/Sensor Feed
Uo:	8.7 V		
Io:	64 mA		
Po:	384 mW		
Lo:	IIC	7.9 mH	
	IIB	38 mH	
Co:	IIC	5.9 µF	
	IIB	50 µF	
Note: Combined Lo and Co for Signal 1 and Signal 2			

This certificate shall only be copied
in its entirety and without change
www.CMLEx.com

2 of 4

Version: 4.0 Approval: Approved

Figure 17: UKEX UK Type Examination Certificate part 2



CML 21UKEX2052X
Issue 1

Power Supply:

Terminals	S3/1	1	L
	S3/2	2	N
Um (U1):	60 V		
Um (U2):	250 V		

Signal Outputs

Terminals:	S2/1	10	Output reference
	S2/2	11	Signal Output 1
	S2/3	12	Signal Output 2
	S2/4	13	Logic Alarm Output
Um:	60 V		

Signal Outputs

Terminals:	S3/3	6	Relay Alarm Output
	S3/4	8	Relay Alarm Output
Um:	60 V		
Relay Contacts:	30 Vdc, 2 A		

Variation 1

This variation introduces the following modifications:

- i. Increase the upper temperature range from +50°C to +60°C
- ii. Update applied standard- EN 60079-0:2012: A11:2013 Corr3 to EN IEC 60079-0:2018

12 Certificate history and evaluation reports

Issue	Date	Associated report	Notes
0	22 Apr 2021	R13681C/00	Issue of prime certificate
1	03 Apr 2024	R17191A/00	Introduction of Variation 1

Note: Drawings that describe the equipment are listed in the Annex.

13 Conditions of Manufacture

The following conditions are required of the manufacturing process for compliance with the certification.

- i. Where the product incorporates certified parts or safety critical components, the manufacturer shall ensure that any changes to those parts or components do not affect the compliance of the certified product that is the subject of this certificate.

This certificate shall only be copied
in its entirety and without change
www.CMLEx.com

3 of 4

Version: 4.0 Approval: Approved

Figure 18: UKEX UK Type Examination Certificate part 3



CML 21UKEX2052X
Issue 1

- ii. IEC 60079-11:2011 CL 11.2 Routine Tests for Infallible Transformers All transformers are subjected to following routine verification and test voltages:

- 2,500 V, between input and output windings;
- 1,000 V between all the windings and the core;
- 1,500 V between each winding which supplies an intrinsically safe circuit and any other output winding;

The test voltage shall be applied for a period of at least 60 s.

Alternatively, the test may be carried out at 1,2 times the test voltage, but with reduced duration of at least 1 s.

The applied voltage shall remain constant during the test. The current flowing during the test shall not increase above that which is expected from the design of the circuit and shall not exceed 5 mA r.m.s. at any time. During these tests, there shall be no breakdown of the insulation between windings or between any winding and the core or the screen.

14 Special Conditions for Safe Use (Conditions of Certification)

The following conditions relate to safe installation and/or use of the equipment.

- i. The values of Co and Lo apply when one of the two conditions below is given:
- The total Li of the external circuit (excluding the cable) is < 1% of the Lo value, or
 - The total Ci of the external circuit (excluding the cable) is < 1% of the Co value.

The above parameters are reduced to 50% when both of the two conditions below are given:

- The total Li of the external circuit (excluding the cable) > 1% of the Lo, and
- The total Ci of the external circuit (excluding the cable) > 1% of the Co.

Note: the reduced capacitance of the external circuit (including cable) shall not be greater than 1 uF for IIB and 600 nF for IIC.

This certificate shall only be copied
in its entirety and without change
www.CMLEx.com

4 of 4

Version: 4.0 Approval: Approved

Figure 19: UKEX UK Type Examination Certificate part 4

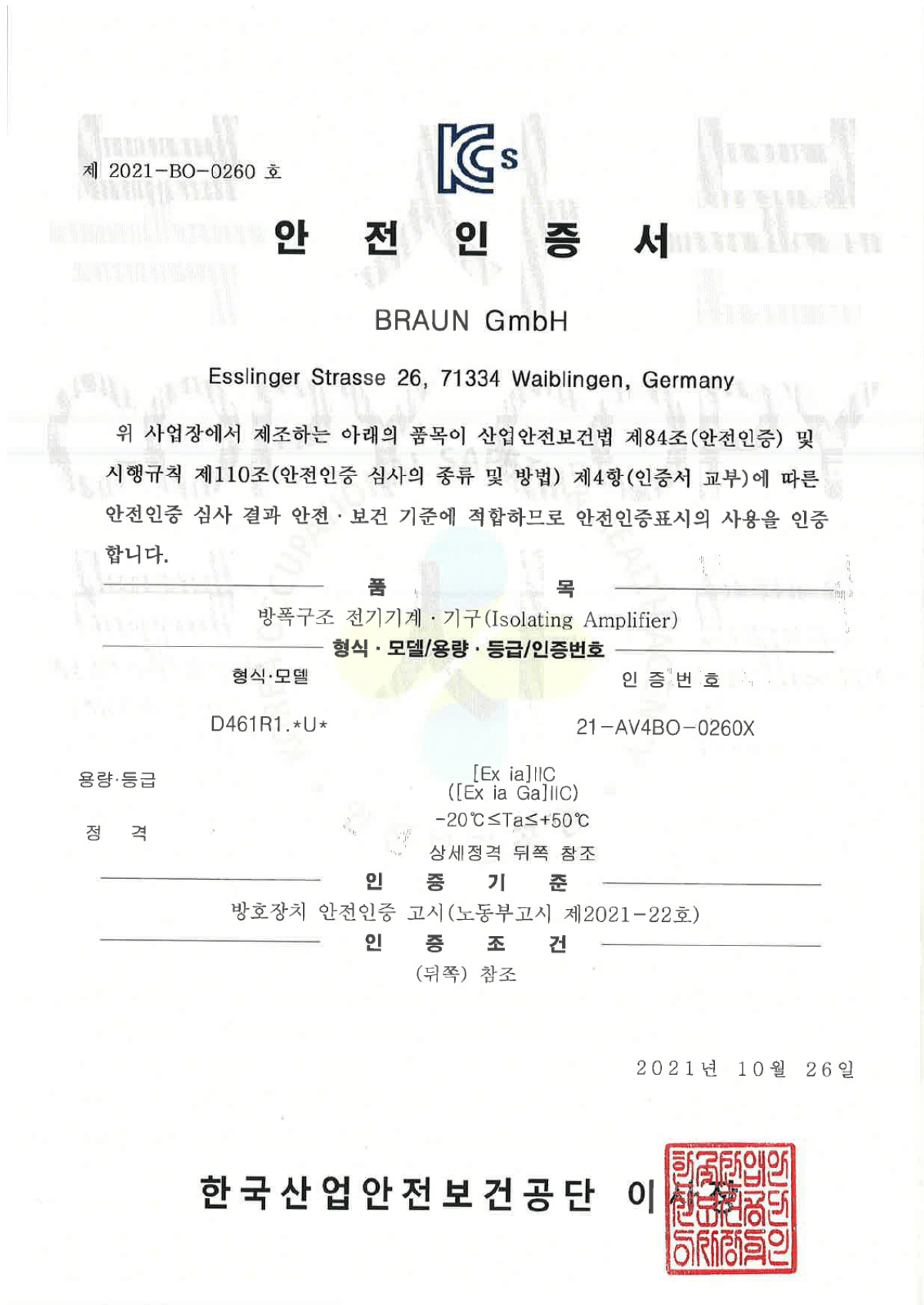

Figure 20: KCs Certificate part 1

(뒤쪽)

부품 인증 조건서

1. 제조공장

- 'Esslinger Strasse 26, 71334 Waiblingen, Germany' 에서 생산하는 제품에 한함.

2. 인증범위

1) 동일형식 범위

D461	R1.	*	U	*
(A)	(B)	(C)		(D)

(A) : Type of Device

(B) : Release 1

(C) : 11 Device one signal channel input, one signal channel output.

12 Device one signal channel input, two signal channel output parallel.

21 Device two signal channel input, two signal channel output.

(D) : 1 Supply Voltage 18 to 40 Vac/dc

2 Supply Voltage 85 to 250 Vac

2) 전기적 파라미터

IS sensor outputs				Power Supply			
Terminals:	S1/4	22	Signal 2	Terminals:	S3/1	1	L
	S1/3	23	Signal 1		S3/2	2	N
	S1/2	24	+Sensor Feed	Um (U1):	60 V		
	S1/1	25	GND/Sensor Feed	Um (U2):	250 V		
Uo:	8.7 V						
Io:	64 mA						
Po:	384 mW						
Lo:	IIC	7.9 mH					
	IIB	38 mH					
Co:	IIC	5.9 μF					
	IIB	50 μF					
Note: Combined Lo and Co for Signal 1 and Signal 2							
Signal Outputs							
Terminals:	S2/1	10	Output reference				
	S2/2	11	Signal Output 1				
	S2/3	12	Signal Output 2				
	S2/4	13	Logic Alarm Output				
Uo:	60 V						
Terminals:	S3/3	6	Relay Alarm Output				
	S3/4	8	Relay Alarm Output				
Um:	60 V						
Relay Contacts:	30 Vdc, 2 A						

3. 안전한 사용을 위한 조건

1) 아래 두 조건중 하나가 적용될 때 Co 및 Lo 값 적용.

- 케이블을 제외한 외부회로의 총 Li 값 < Lo 값의 1% 일 때,

- 케이블을 제외한 외부회로의 총 Ci 값 < Co 값의 1% 일 때,

2) 아래 두 조건 모두 적용될 때 Co 및 Lo 값의 50% 감소된 값 적용.

- 케이블을 제외한 외부회로의 총 Li 값 > Lo 값의 1% 일 때,

- 케이블을 제외한 외부회로의 총 Ci 값 > Co 값의 1% 일 때

4. 인증(변경)사항

- 없음.

5. 그 밖의 사항

- 안전인증품의 품질관리, 확인검사 수검, 변경사항 신고 등 인증 받은 자의 의무 준수.

Figure 21: KCs Certificate part 2

2.3.13 Control Drawing D461R1.11

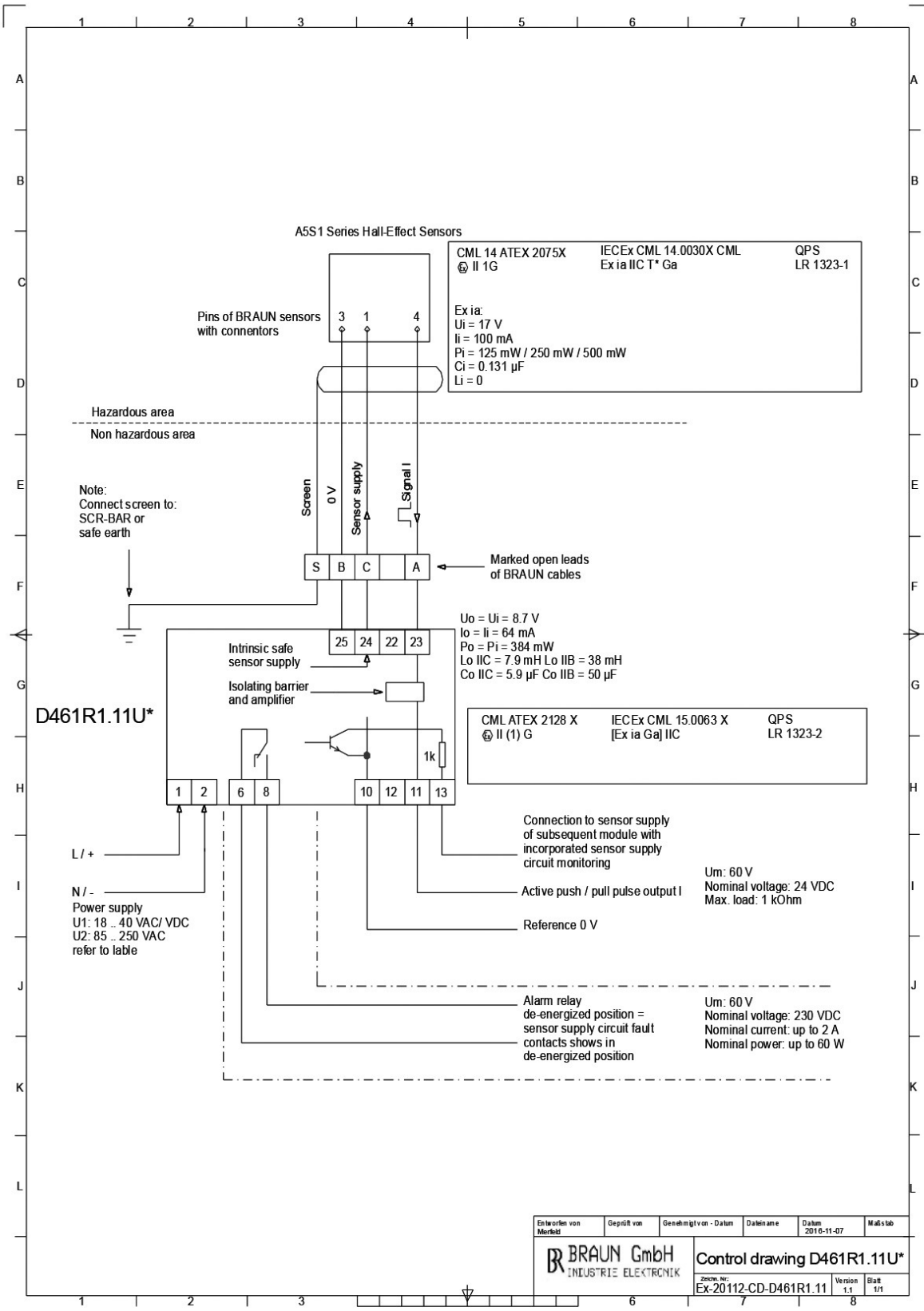

Figure 22: Control Drawing D461R1.11

2.3.14 Control Drawing D461R1.12

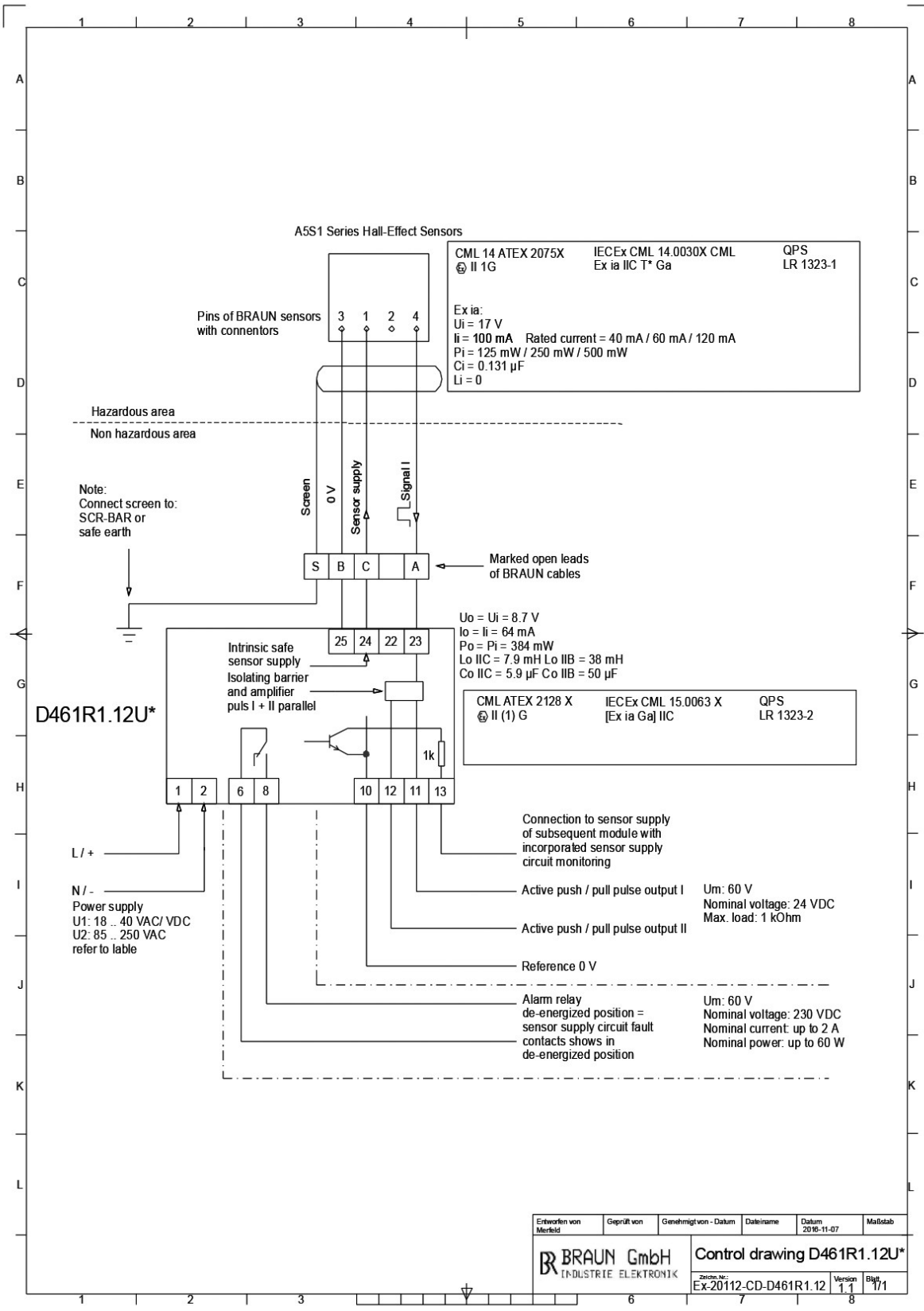

Figure 23: Control Drawing D461R1.12

2.3.15 Control Drawing D461R1.21

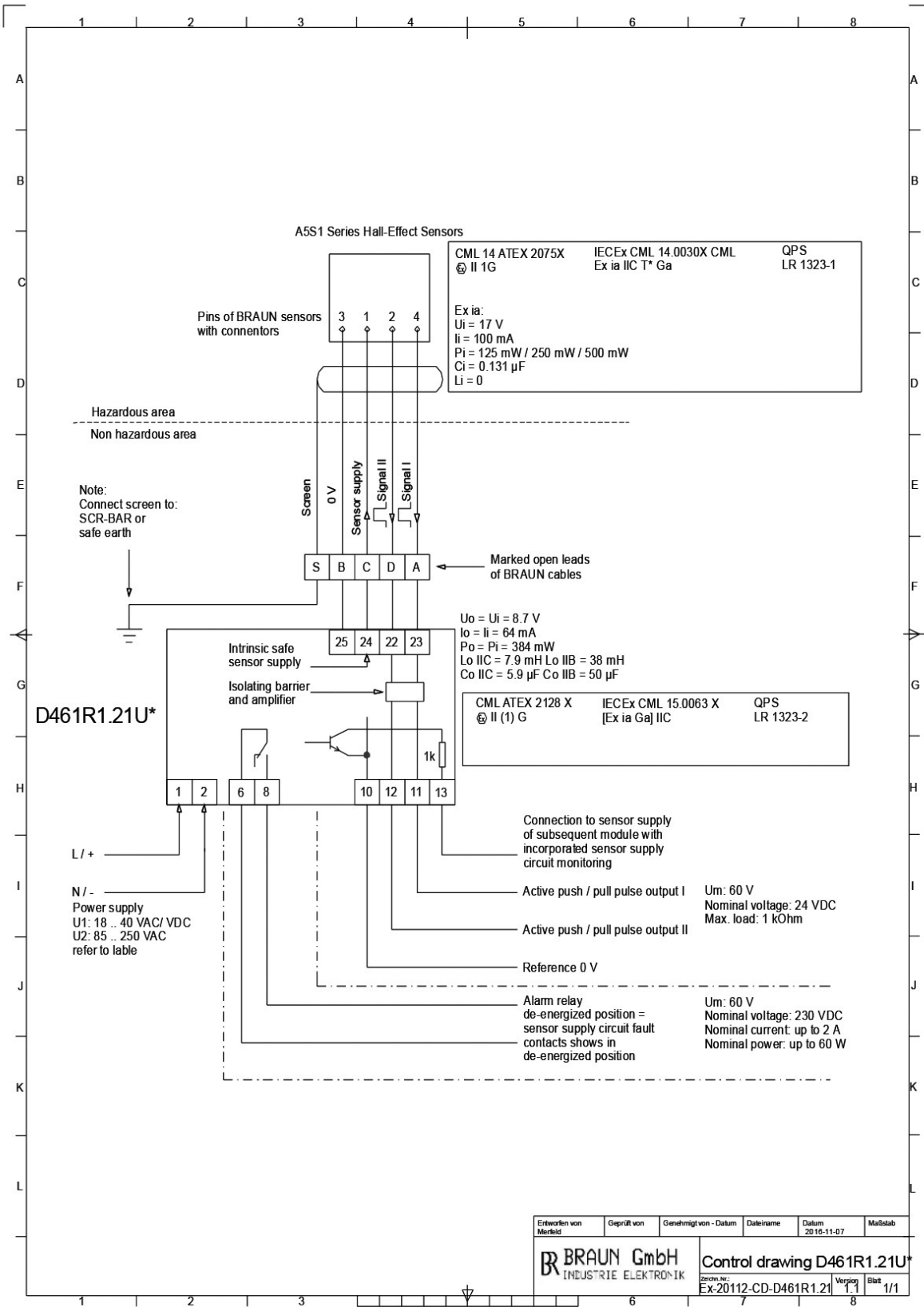

Figure 24: Control Drawing D461R1.21

3 Function Diagram and Connections

3.1 Function Diagram and Connection D461R1.11

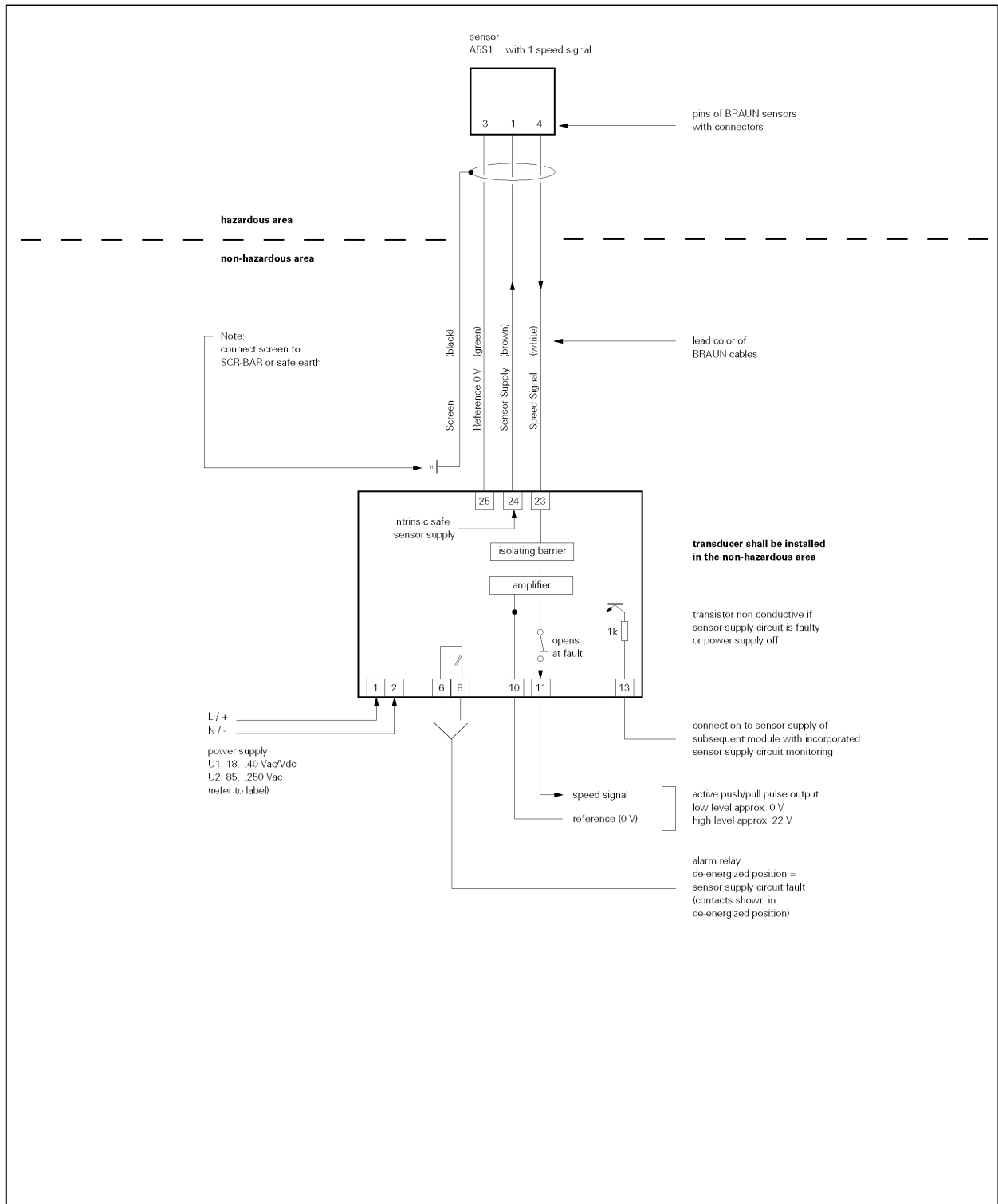

Figure 25: Function Diagram and Connection D461R1.11

3.2 Function Diagram and Connection D461R1.12

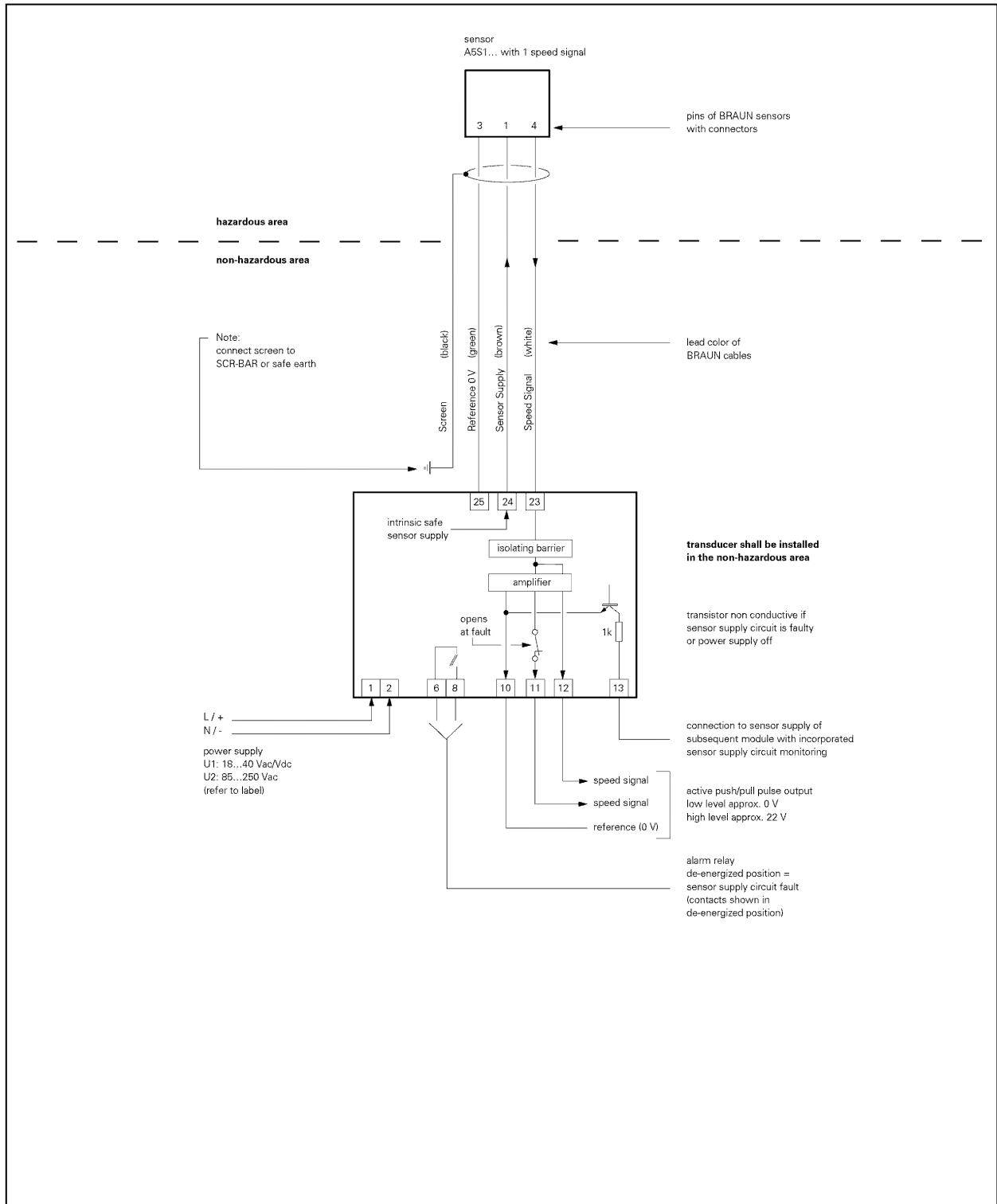

Figure 26: Function Diagram and Connection D461R1.12

3.3 Function Diagram and Connection D461R1.21

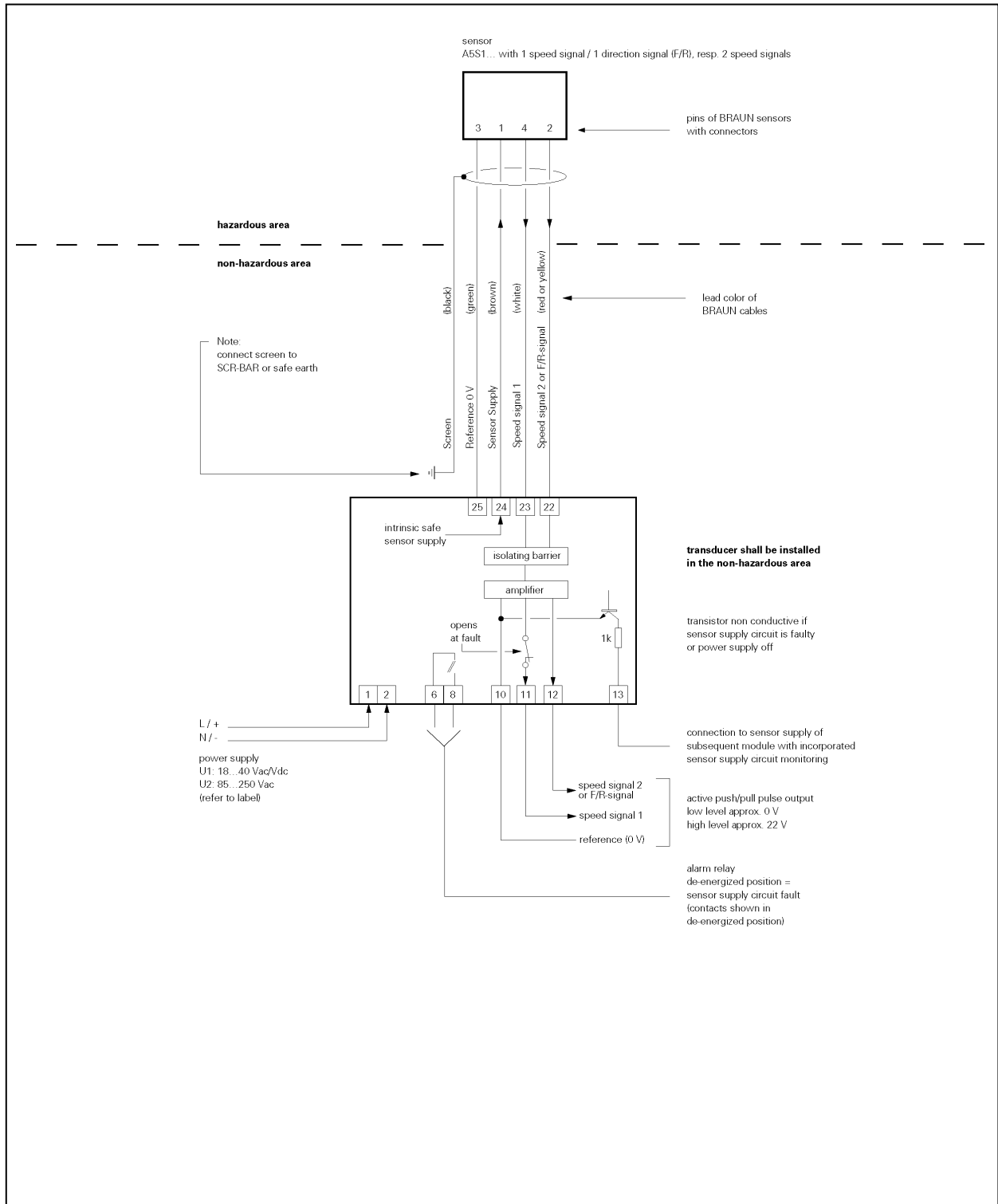

Figure 27: Function Diagram and Connection D461R1.21

4 Technical Specifications

4.1 Technical Data of Inputs (intrinsic safe)

Response level 4 V, Input impedance approx. 47 k.

Sensor supply (operational value) 8 volts.

Approved maximum values:	U _o	= 8.7 V
	I _o	= 64 mA
	P _o	= 384 mW
	L _o	= 7.9 mH (IIC)
		= 38 mH (IIB)
	C _o	= 5.9 µF (IIC)
		= 50 µF (IIB)

Versions D461R1.11 and D461R1.12

The sensor has to be connected to the signal input by 3 leads shielded cable. Recommended wire cross section LiYCY 3x0.34 or larger.

Version D461R1.21

The sensor has to be connected to the signal input by 4 leads shielded cable. Recommended wire cross section LiYCY 4x0.34 or larger.

4.2 Technical Data of Outputs

Outputs are short-circuit-proof and free-floating versus power supply and input.

Active pulses by push-pull transistor output stage, sequence inverting the input signal.

Output level with maximum load towards 0 V:	High-Level approx. 18 V
	Low-Level 0 V

Output level with maximum load towards 24 V:	High-Level approx. 20 V
	Low-Level approx. 2 V

Version D461R1.11 incorporates one signal output, versions D461R1.12 and D461R1.21 incorporate two signal outputs each.

4.3 Technical Data of Power Supply

D461R1.xxU1: 18...40 Vac/Vdc, power requirements approx. 5 VA.

D461R1.xxU2: 85...250 Vac, power requirements approx. 5 VA.

4.4 Environmental conditions

Ambient temperature in operation: -20 °C...+60 °C

Ambient temperature in storage: -20 °C...+85 °C

Relative humidity: < 95%, non-condensing

To be installed in dry cabinets in air-conditioned rooms

Up to 2000 meters above sea level

4.5 Protection Grade

Protection Grade: IP20

As a special version, the barrier is available in enclosure grade IP65 (NEMA4), or in explosion-proof enclosure (Exd II C T5).

4.6 Connectors

Connectors with screw terminals

4.7 Conformity to Standards

Directives

2014/34/EU	ATEX Product Directive
2014/30/EU	EMC Directive
2014/35/EU	Low Voltage Directive (LVD)
2011/65/EU	RoHS Directive

Standards

EN IEC 60079-0, EN 60079-11
EN 61326-1, EN IEC 61326-3-2
EN 61010-1
EN IEC 63000

UK statutory requirements

SI 2016 No. 1107 (amended by SI 2019 No. 696)

Standards

BS EN IEC 60079-0
BS EN 60079-11

4.8 Dimensions

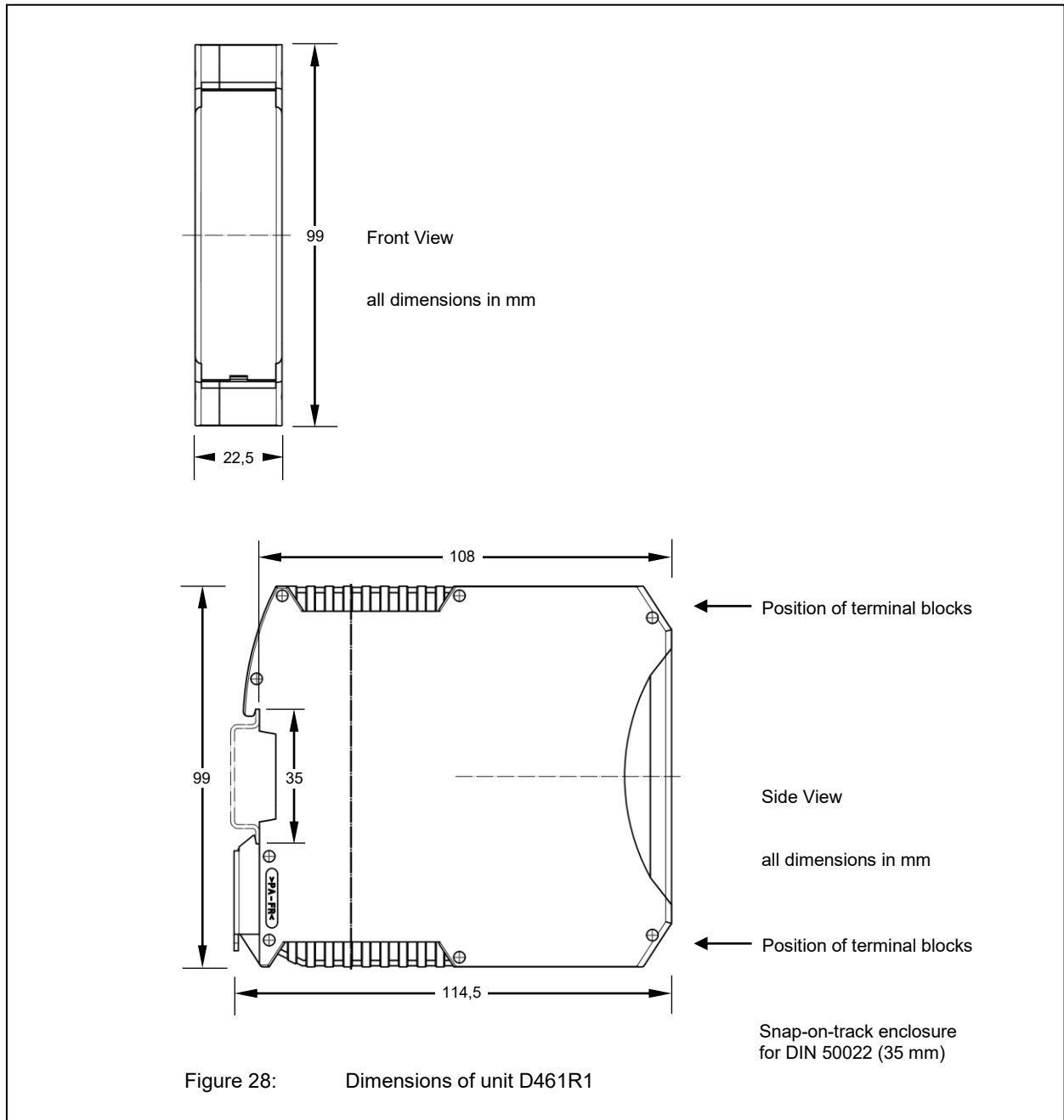

4.9 Weight

Approx. 0.4 kg.

5 Safety Notes for Installation and Operation

5.1 Safety Notes for Installation

The isolating barriers series D461R1... has been designed and tested according to the standards EN 61010-1 (VDE 0411-1) and have left the factory in perfect safety condition. To maintain this condition and to ensure safe operation, the user must observe the notes and wiring diagrams contained in this operating manual.

Installation and maintenance work must be done only by adequately qualified personnel and only when the power supply is switched off.

5.1.1 General Instructions

The isolating barriers series D461R1... shall be installed in the non-hazardous area, resp. protected by an explosion-proof enclosure.

5.1.2 EMI

The isolating barriers series D461R1... complies with all relevant regulations, as determined by the Policy of the European Committee for Electrotechnical Standardization (CENELEC), for the Electromagnetic Compatibility (2014/30/EU). Testing and inspection have been performed according to Standards EN 61326-1 and EN IEC 61326-3-2. Thereby, the product meets all requirements to be marked by the CE sign.

Strict observance of these instructions during installation and use is an indispensable precondition hereto.

5.2 Safety Notes for Operation

5.2.1 Safety Notes on Commissioning

Commissioning must be carried out by sufficiently competent and qualified personnel.

During commissioning of the entire machine, the commissioning technician must ensure that the measuring chains function properly.

Date	Rev.	Modification
03.02.2017	00	First Edition
08.09.2017	01	Editorial: Chapter 1.7.1, 4.7 and 5.1.2: Adaptation of EMI Standards
13.02.2018	01	Editorial: Chapter 2.3.4 and 2.3.10: Insert the EAC approval Chapter 2.3.8: Integration of new IECEX Certificate of Conformity (Issue No. 1)
23.01.2019	01	Editorial: New ATEX EU Type Examination Certificate in chapter 2.3.7 inserted and EU Declaration of Conformity in chapter 1.7.1 adapted.
28.06.2019	01	Editorial: Chapter 2.3.3 NEC/CEC and 2.3.9 NEC/CEC Certificate of Conformity inserted.
19.01.2021	01	Editorial: EU Declaration of Conformity in chapter 1.7.1 adapted.
28.04.2021	01	Editorial: Chapter 2.3.5 UKEX and 2.3.11 UKEX UK Type Examination Certificate inserted.
18.01.2022	02	Editorial: Chapter 2.3.6 KCs and 2.3.12 KCs Certificate inserted. Technical: Chapter 1.4 and chapters 3.1, 3.2 and 3.3 adapted.
01.04.2022	03	Editorial: Update of the EU declaration of conformity in chapter 1.7.1 Editorial and Technical: No sensor fault alarm via terminals 6 and 8. If a sensor fault is detected, the signal output (terminal 11) is switched to high resistance (output opened via relay). Change in chapter 1.4. Functional overview and connection diagram with chapters 3.1, 3.2 and 3.3 adjusted. Change is effective for devices with serial number from 2205010000.
23.12.2022	04	Editorial and Technical: Sensor fault alarm via terminals 6 and 8 available again. Change in chapter 1.4. (now with 1.4.1 and 1.4.2) Functional overview and connection diagram with chapters 3.1, 3.2 and 3.3 adjusted. Change is effective for devices with serial number from 2301010000.
05.04.2024	05	Editorial: Update of the EU declaration of conformity in chapter 1.7.1. Adaptation of Standard EN IEC 60079-0 and BS EN IEC 60079-0 in chapter 4.7. Integration of control drawings in chapters 2.3.13, 2.3.14 and 2.3.15. Editorial and Technical: Increase of temperature range from +50 to +60 °C in chapter 4.4 and with change of the corrected certificates.
28.06.2024	06	Editorial: Chapter 1.8 inserted and minor editorial corrections.



Protecting Your Rotating Equipment

D 71334 Waiblingen-Hegnach
Esslinger Str. 26
Phone: +49 (0)7151/956230
E-Mail: info@braun-tacho.de
Internet: www.braun-tacho.de